

LEGEND

DETAIL SECTION		AD	AREA DRAIN	+00.00	PROPOSED ELEVATION	< 0.0 %	DIRECTION OF SLOPE
DETAIL NUMBER		BW	BOTTOM OF WALL		TOP OF WALL	+TS	TOP OF STAIRS
SHEET ON WHICH DETAIL IS SHOWN		CJ	CONTROL JOINT		BOTTOM OF WALL	+BS	BOTTOM OF STAIRS
PRIMARY SECTION		EJ	EXPANSION JOINT		FINISH FLOOR ELEVATION	+TC	TOP OF CURB
EXTERIOR ELEVATION		EQ	EQUIDISTANT		TOP OF BENCH	+BC	BOTTOM OF CURB
REVISION		PA	PLANTING AREA		AREA DRAIN	+EX 00.00	EXISTING SPOT ELEVATION AS PER SURVEY
		PD	PLANTER DRAIN				
		RD	RADIUS				
		TW	TOP OF WALL				
		TYP	TYPICAL				
		HOB	HOSE BIB				
		TD	TRENCH DRAIN				

NOTES

1. ALL DIMENSIONS ARE NOMINAL; DIMENSIONS ARE BASED ON ARCHITECTURAL GRID.
2. REFER TO DETAILS AND SECTIONS FOR ALL LANDSCAPE IMPROVEMENTS.
3. ALIGN SAW CUT WITH BUILDING MULLION, EXCEPT WHERE SHOWN OTHERWISE. CONFIRM PATTERN ON SITE WITH LANDSCAPE ARCHITECT.
4. REFER TO SPECIFICATIONS FOR MATERIALS AND INSTALLATION REQUIREMENTS. REFER TO SOIL DEPTH DETAILS FOR SOIL DEPTH AND VOIDING.
5. ALL ELEVATIONS ARE NOMINAL AND ARE BASED ON ARCHITECTURAL GRID AND ELEVATIONS PROVIDED BY ARCHITECT. CONTRACTOR TO VERIFY ALL MEASUREMENTS.
6. ALL PROPOSED ELEVATIONS ARE TO TOP OF FINISHED GRADE UNLESS NOTED OTHERWISE.
7. PAVING IS GRADED TO A TYPICAL DIMENSION ABOVE STRUCTURAL SLABS. REFER TO PAVING DETAILS FOR TYPICAL ELEVATION OF SLAB.
8. PAVING, PLANTING, LIGHTING AND FURNISHINGS TO BE COMPLIANT WITH UBC CAMPUS PLAN DESIGN GUIDELINES.

PLANT SCHEDULE

KEY	QTY	BOTANICAL NAME	COMMON NAME	PLANTED SIZE	COMMENTS
PM	8	PRUNUS MUME	WINTER PLUM	7.0CM CAL, B&B	UNIFORM SIZE AND QUALITY

Shrubs and Groundcovers

TB	400	TAXUS X BACCATA 'REPANDENS'	SPREADING YEW	#3 POT, 450MM OC	FULL AND WELL ESTABLISHED
PT	200	PACHYSANDRA TERMINALIS	JAPANESE SPURGE	#1 POT, 450MM OC	FULL AND WELL ESTABLISHED

NOTES

1. ALL PLANT MATERIAL TO BCNTA AND BCSLA STANDARDS. REFER TO THE BCSLA LANDSCAPE STANDARD, LATEST EDITION.
2. AREA OF SEARCH FOR PLANT MATERIAL: PACIFIC NORTHWEST, INCLUDING BRITISH COLUMBIA, WASHINGTON AND OREGON.
3. REFER TO SPECIFICATION FOR GENERAL CONDITIONS, MATERIALS AND INSTALLATION REQUIREMENTS.
4. CONFIRM TREE PLANTING LOCATIONS, AND PLANTING LAYOUT WITH LANDSCAPE ARCHITECT ON SITE.
5. NO SUBSTITUTIONS OF ANY PLANT MATERIAL WILL BE APPROVED WITHOUT SUBMITTAL REVIEW AND APPROVAL BY THE CLIENT/LANDSCAPE ARCHITECT.
6. ALL PLANTING TO BE COMPLIANT WITH UBC CAMPUS PLAN DESIGN GUIDELINES.
7. ALL PLANTING TO BE IRRIGATED TO UBC TECHNICAL SPECIFICATIONS.

BIKE RACKS

TOTAL	SPACES
28	56

Drawing scale may be affected by printing, scanning or copying. © 2012 OMB. ALL RIGHTS RESERVED.

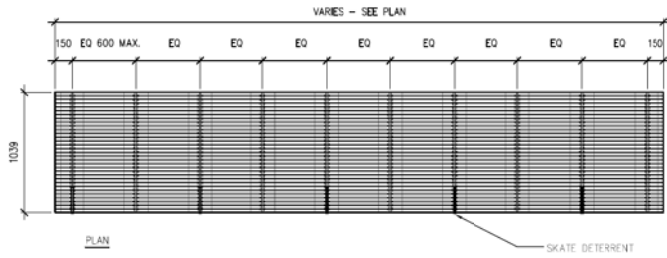

NOTES:
 CONCRETE : TC = 32 MPa, C-2
 SAWCUT CONTROL JOINTS 4MM X 25 MM DP. IN GRID, SEE LAYOUT PLAN, WITHIN 18 HOURS OF FINISHING SLABS, ZIP STRIP MUST BE APPROVED BY ARCHITECT

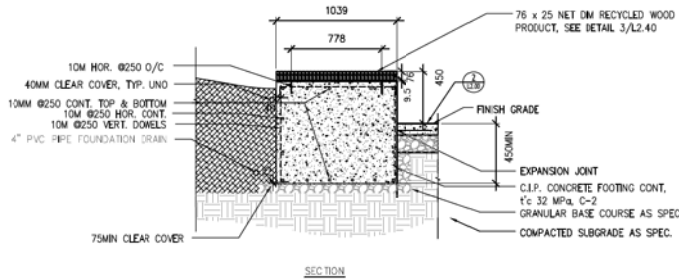

NOTES:
 1. PROVIDE SHOP DRAWINGS FOR BENCH CONSTRUCTION
 2. USE RECYSTA RECYCLED PRODUCT, 1" X 3" CUSTOM PROFILE, FVG-C14 SIAM COLOUR
 3. USE GALVANIZED STEEL FOR ALL HARDWARE UNLESS OTHERWISE NOTED.
 4. REFER TO SPECIFICATIONS FOR CONCRETE FINISHES

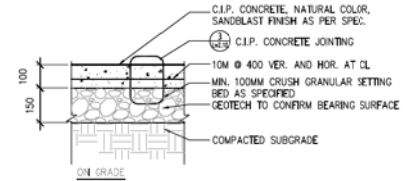

1 Cast Concrete Paving
 12.000 1:10

3 UBC Bench
 12.000 1:20

NOTE:
 CONSTRUCT ALL CONTROL JOINTS AT CONSISTENT WIDTH
 CUT JOINTS BEFORE RANDOM CRACKING OCCURS

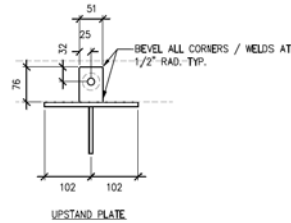
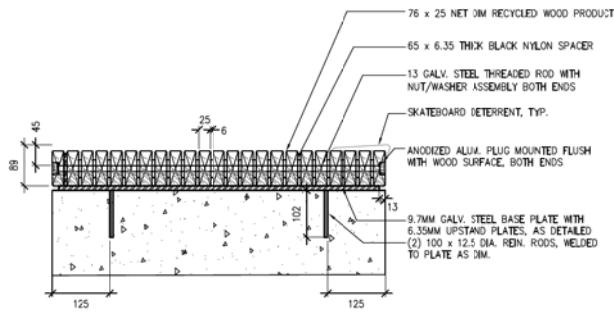

4 Bench Assembly
 12.000 1:5

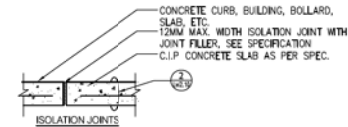
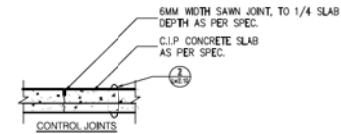

2 Cast Concrete Jointing
 12.000 1:10

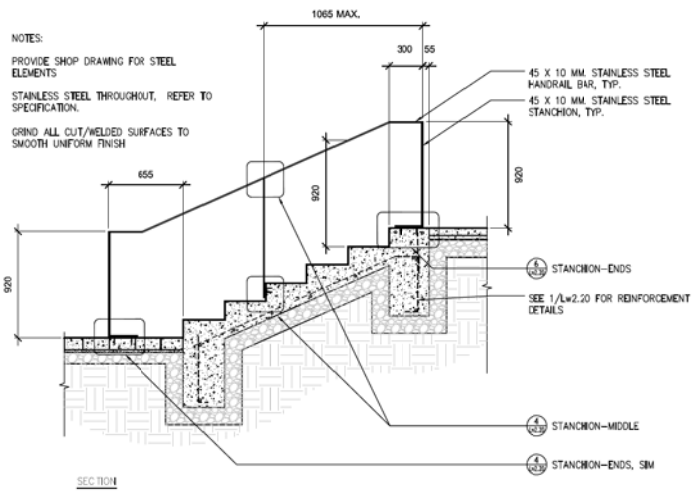

2 Handrail Typ.
L2.10 1:20

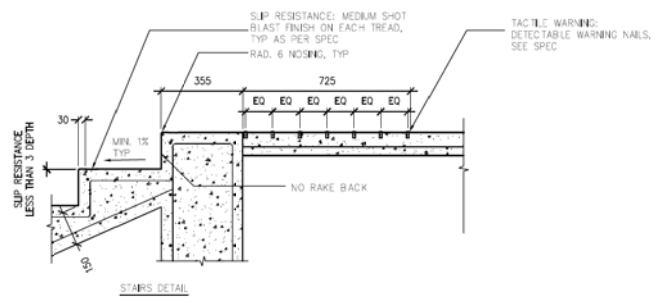

1 Cast Concrete Stair Tactile Warning
L2.10 1:10 DETAIL

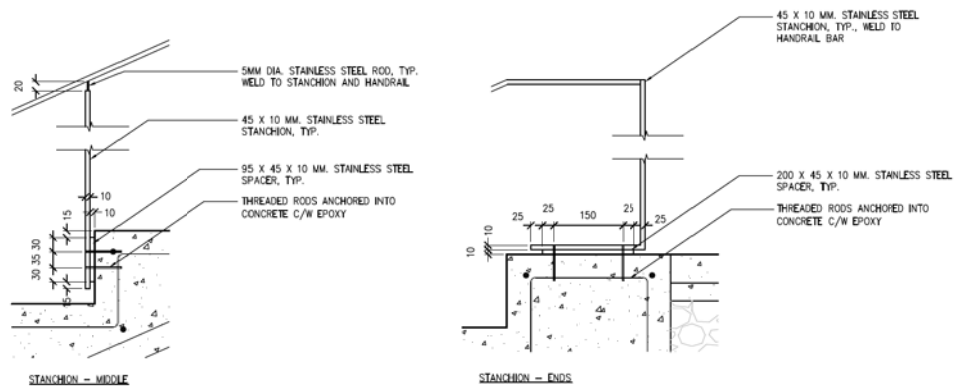

3 Handrail Mount
L2.10 1:5

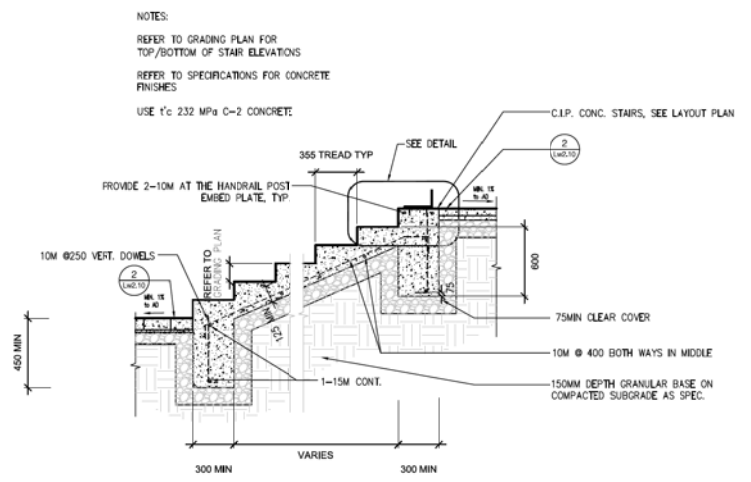

1 Cast Concrete Stairs
L2.10 1:20

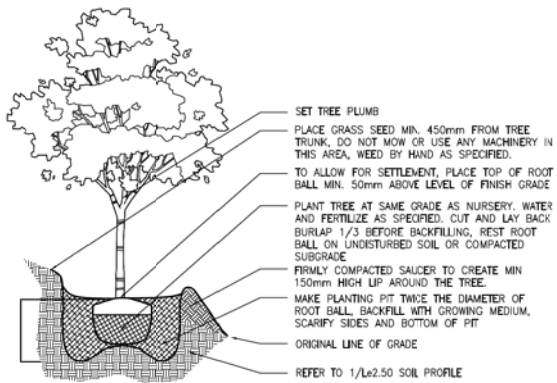

1 Tree Planting on Slope
12.20 NTS

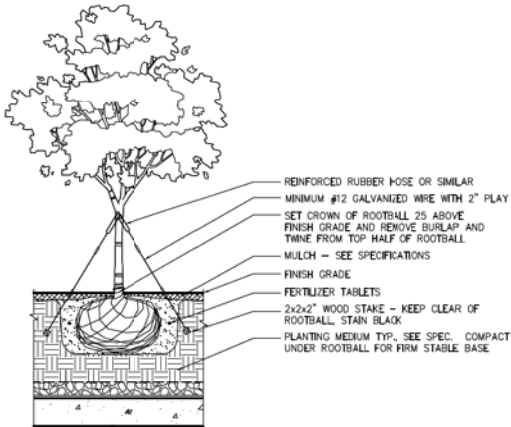

2 Tree Planting
12.20 NTS

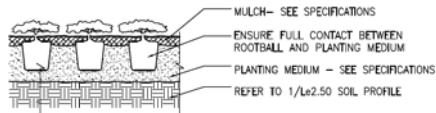
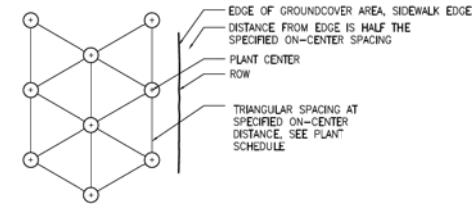

3 Groundcover Planting
12.20 NTS

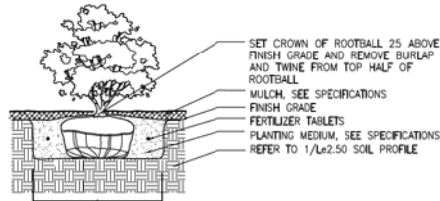

5 Shrub Planting
12.20 NTS

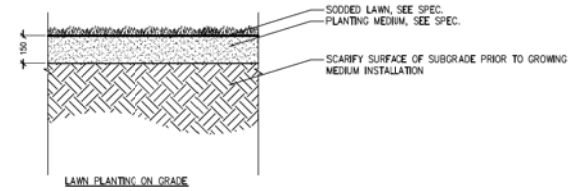

LAWN PLANTING ON GRADE

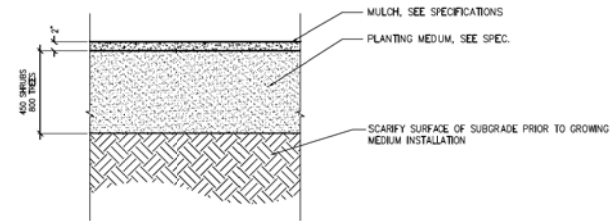

SHRUB/TREE PLANTING ON GRADE

1 Soil Profiles
12.20 NTS