

Copyright reserved
Everything shown hereon for use on this project only and may not be reproduced without the Architect's written permission and unless the reproduction carries their name.

Landscape Drawing List

L-0.00	Landscape Context Plan
L-1.00	Landscape Layout & Lighting North
L-1.01	Landscape Layout & Lighting Centre
L-1.02	Landscape Layout & Lighting South
L-2.00	Landscape Planting Plan - North
L-2.01	Landscape Planting Plan - Central
L-2.02	Landscape Planting Plan - South
L-2.03	Landscape Planting Plan - Roof North
L-2.04	Landscape Planting Plan - Roof South
L-3.00	Landscape - Sections
L-3.01	Landscape - Sections
L-4.00	Landscape - Details
L-4.01	Landscape - Details
L-4.02	Landscape - Details
L-4.03	Landscape - Details
L-4.04	Landscape - Details
L-5.00	Landscape - Plant List Images
L-5.01	Landscape - Plant List Images

2	Issue for DP	2022.01.07
1	Development Application AUDP	2022.01.04
No.	Description	Date

SEAL:

PROJECT:

Carey Theological College
LOT 40 & LOT 42
5920 Iona Drive
Vancouver, BC

PROJECT NO.: DP 2022 0104

CONSULTANTS:

DRAWN BY:

MRM

FILE NO.:

DATE:

2021.01.04

SCALE:

As indicated

TITLE:

Landscape Context Plan

SHEET NO.: REVISION:

L-0.00

2

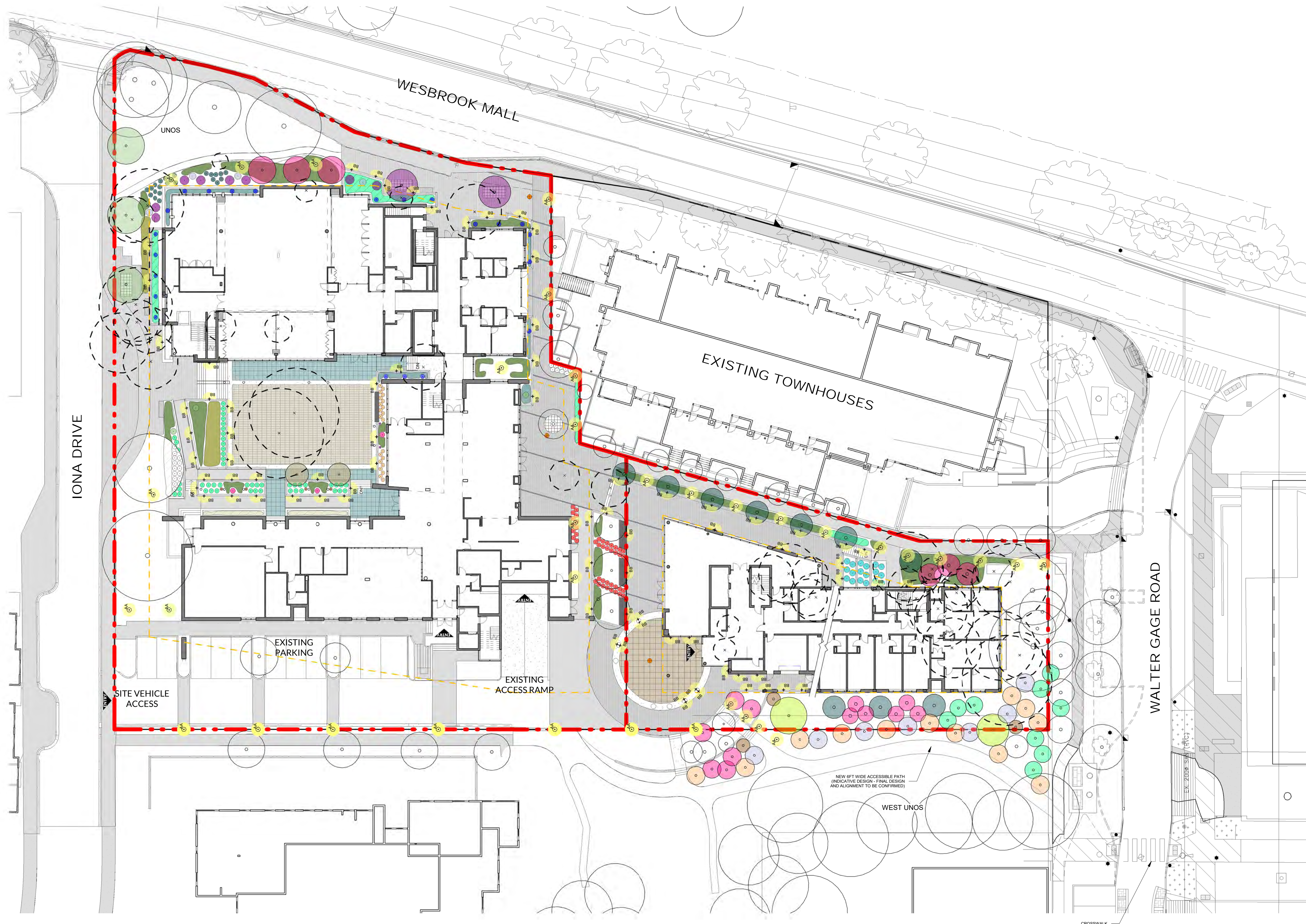

Legend

- CIP Concrete (Natural)
- CIP Concrete (Tinted)
- 24"L x 6"W x 4"deep Conc. Plank Pavers: Colour: Natural Accent Colour: Charcoal
- 24"x 24" Porcelain Pavers Colour: Granite
- 12"x 24" Porcelain Pavers Colour: Sand
- Gravel Strip @ Building Edge
- Green Roof
- 4in W x 4ft Long Granite Strips

2	Issue for DP	2022.01.07
1	Development Application AUDP	2022.01.04
No.	Description	Date

PROJECT:

Carey Theological College
LOT 40 & LOT 42
5920 Iona Drive
Vancouver, BC

PROJECT NO.: DP 2022 0104

CONSULTANTS:

DRAWN BY:

MRM FILE NO.:

DATE:

2021.01.04 SCALE:

As indicated TITLE:

Landscape Layout & Lighting North

SHEET NO.: REVISION:

L-1.00 2

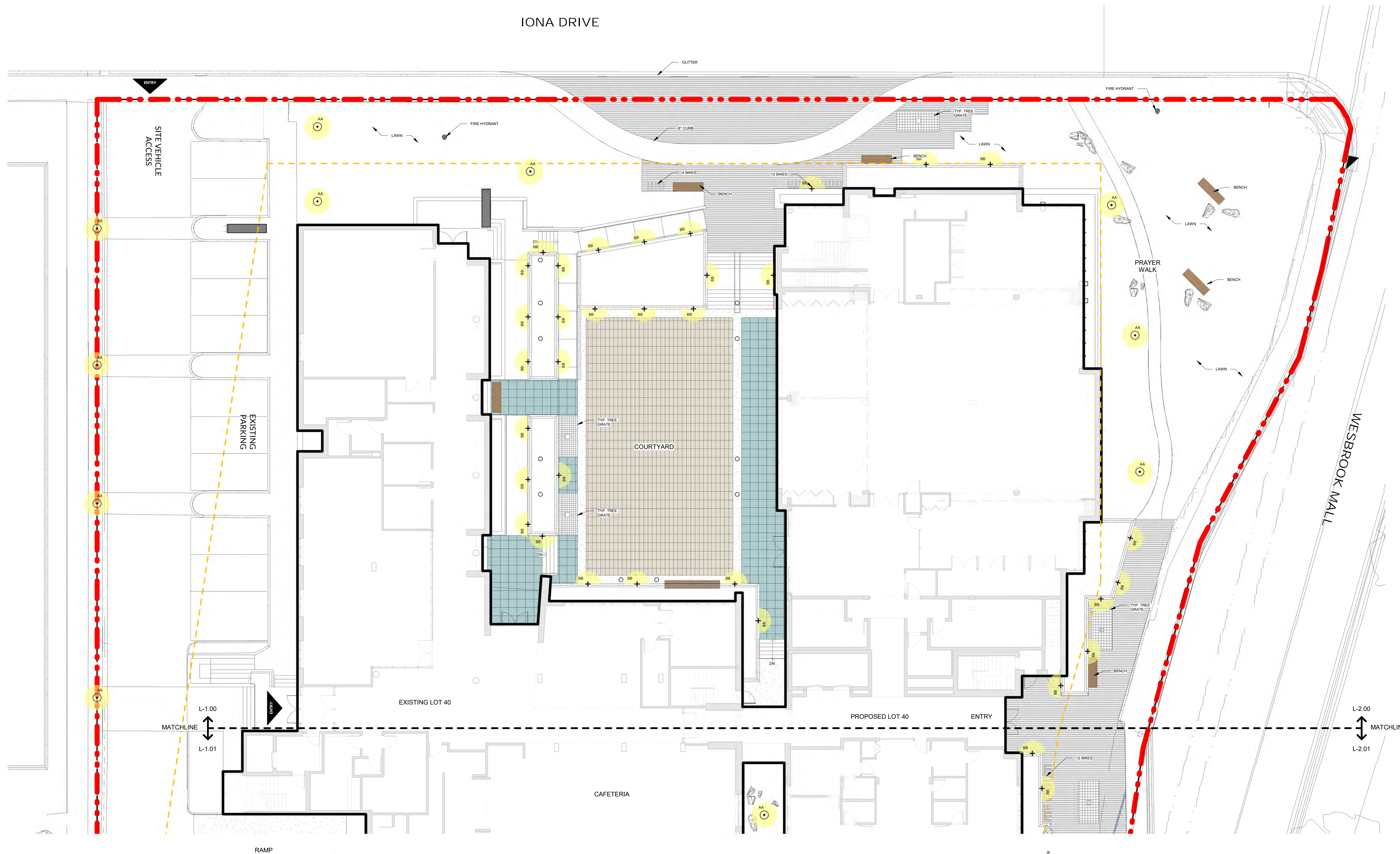

IONA DRIVE



1 Landscape - North
3/32" = 1'-0"

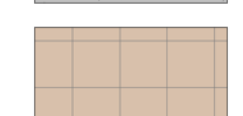
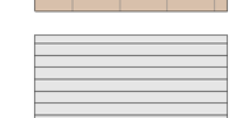
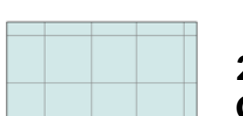
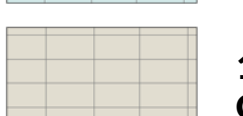
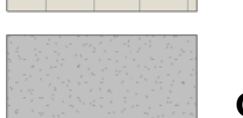

Legend

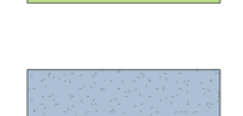
-  CIP Concrete (Natural)
-  CIP Concrete (Tinted)
-  24"L x 6"W x 4"deep Conc. Plank Pavers: Colour: Natural Accent Colour: Charcoal
-  24"x 24" Porcelain Pavers Colour: Granite
-  12"x 24" Porcelain Pavers Colour: Sand
-  Gravel Strip @ Building Edge
-  Green Roof
-  4in W x 4ft Long Granite Strips

Lighting Key

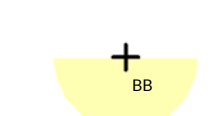
-  Landscape Lighting Fixture Type A
Bollard DG-2 LED 5.0W - 36" H
-  Landscape Lighting Fixture Type B
Bega 33.053 LED - 5.2W

2	Issue for DP	2022.01.07
1	Development Application AUDP	2022.01.04
No.	Description	Date

SEAL:

PROJECT:

Carey Theological College
LOT 40 & LOT 42
5920 Iona Drive
Vancouver, BC

PROJECT NO.: DP 2022 0104

CONSULTANTS:

DRAWN BY:

MRM

FILE NO.:

DATE:

2021.01.04

SCALE:

As indicated

TITLE:

Landscape Layout & Lighting Centre

SHEET NO.: REVISION:



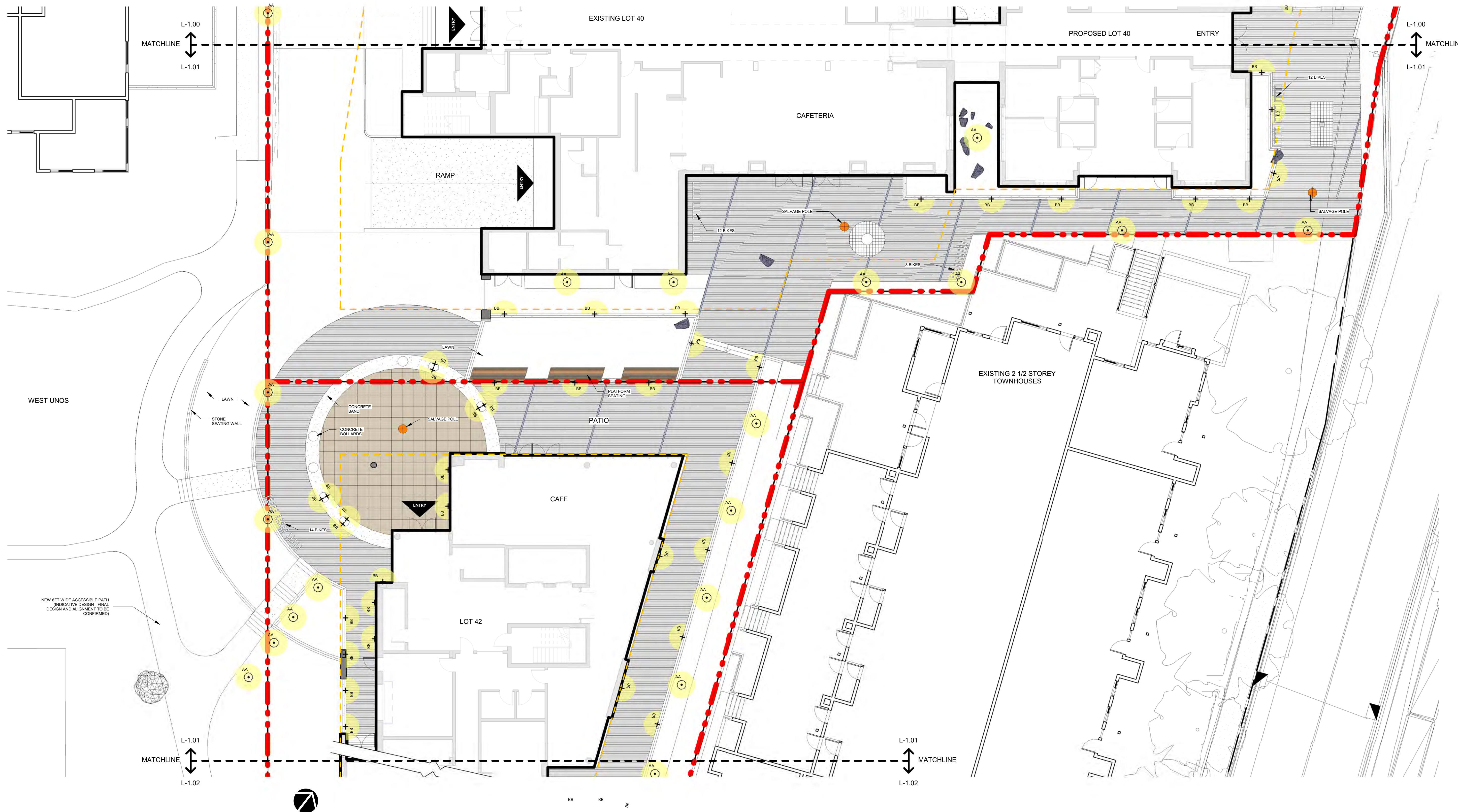

L-1.01

2



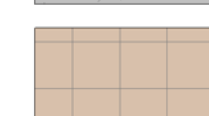
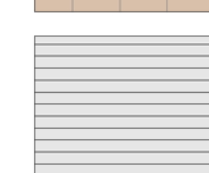

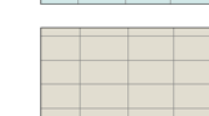
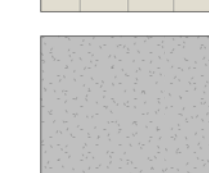
1 Landscape - Centre (Mews)
3/32" = 1'-0"

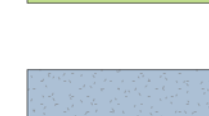
Legend

-  CIP Concrete (Natural)
-  CIP Concrete (Tinted)
-  24"L x 6"W x 4"deep Conc. Plank Pavers: Colour: Natural Accent Colour: Charcoal
-  24"x 24" Porcelain Pavers Colour: Granite
-  12"x 24" Porcelain Pavers Colour: Sand
-  Gravel Strip @ Building Edge
-  Green Roof
-  4in W x 4ft Long Granite Strips

Lighting Key

-  Landscape Lighting Fixture Type A
Bollard DG-2 LED 5.0W - 36" H
-  Landscape Lighting Fixture Type B
Bega 33.053 LED - 5.2W

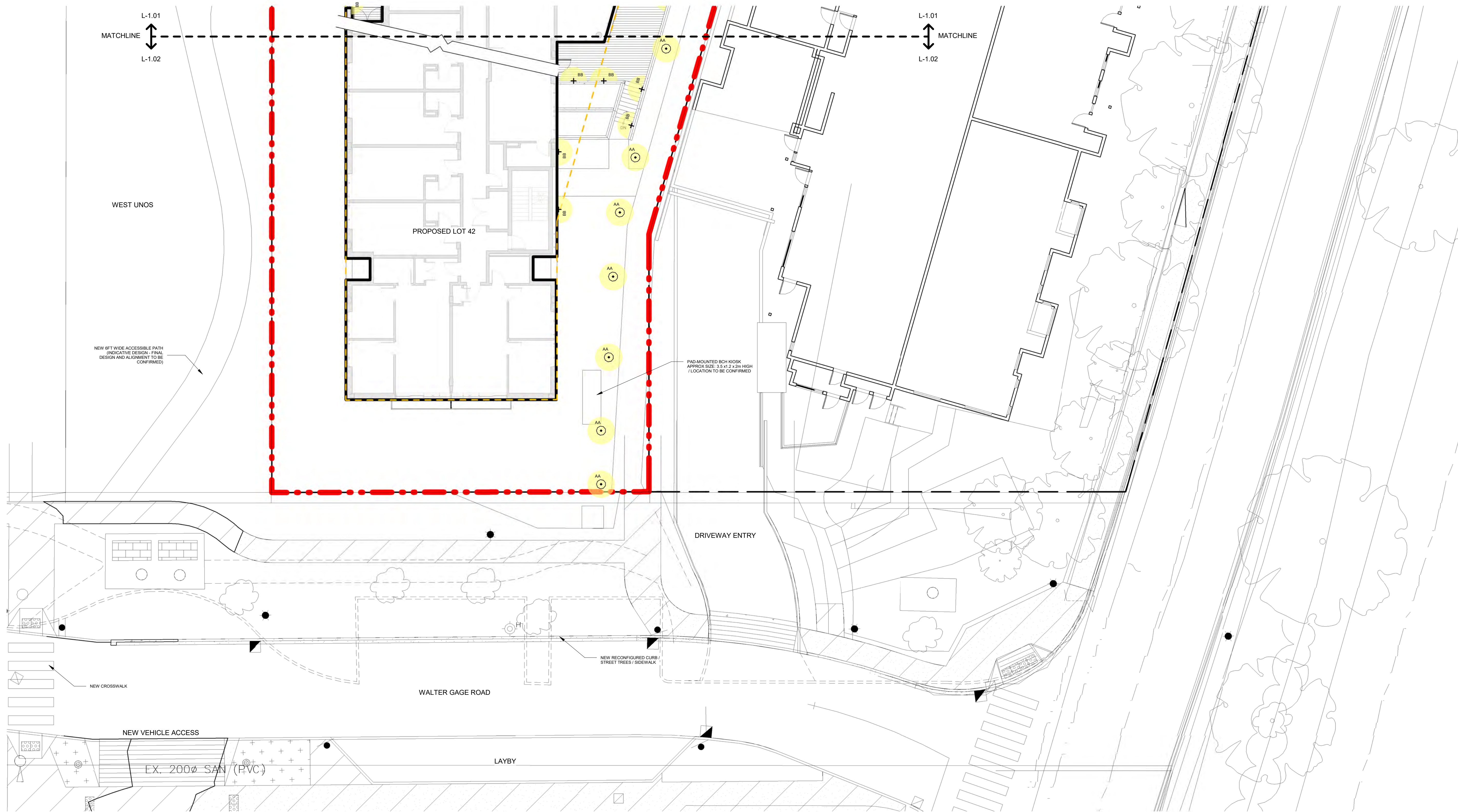

No.	Description	Date
2	Issue for DP	2022.01.07
1	Development Application AUDP	2022.01.04

SEAL:

PROJECT:
Carey Theological College
LOT 40 & LOT 42
5920 Iona Drive
Vancouver, BC

PROJECT NO.: DP 2022 0104

CONSULTANTS:

DRAWN BY:
MRM

DATE:
2021.01.04

SCALE:
As indicated

TITLE:
Landscape Layout & Lighting South

SHEET NO.: REVISION:

L-1.02 2

1 Landscape - South (Gage)
3/32" = 1'-0"



Legend

- CIP Concrete (Natural)
- CIP Concrete (Tinted)
- 24"L x 6"W x 4" deep Conc. Plank Pavers: Colour: Natural Accent Colour: Charcoal
- 24"x 24" Porcelain Pavers Colour: Granite
- 12"x 24" Porcelain Pavers Colour: Sand
- Gravel Strip @ Building Edge
- Green Roof
- 4in W x 4ft Long Granite Strips

Lighting Key

- Landscape Lighting Fixture Type A
Bollard DG-2 LED 5.0W - 36" H
- Landscape Lighting Fixture Type B
Bega 33.053 LED - 5.2W

2	Issue for DP	2022.01.07
1	Development Application AUDP	2022.01.04
No.	Description	Date

PROJECT NO.: DP 2022 0104

PROJECT:
Carey Theological College
LOT 40 & LOT 42
5920 Iona Drive
Vancouver, BC

CONSULTANTS:

DRAWN BY:
MRM

FILE NO.:

DATE:
2021.01.04

SCALE:
3/32" = 1'-0"

TITLE:
Landscape Planting Plan - North

SHEET NO.: REVISION:

L-2.00 **2**

IONA DRIVE

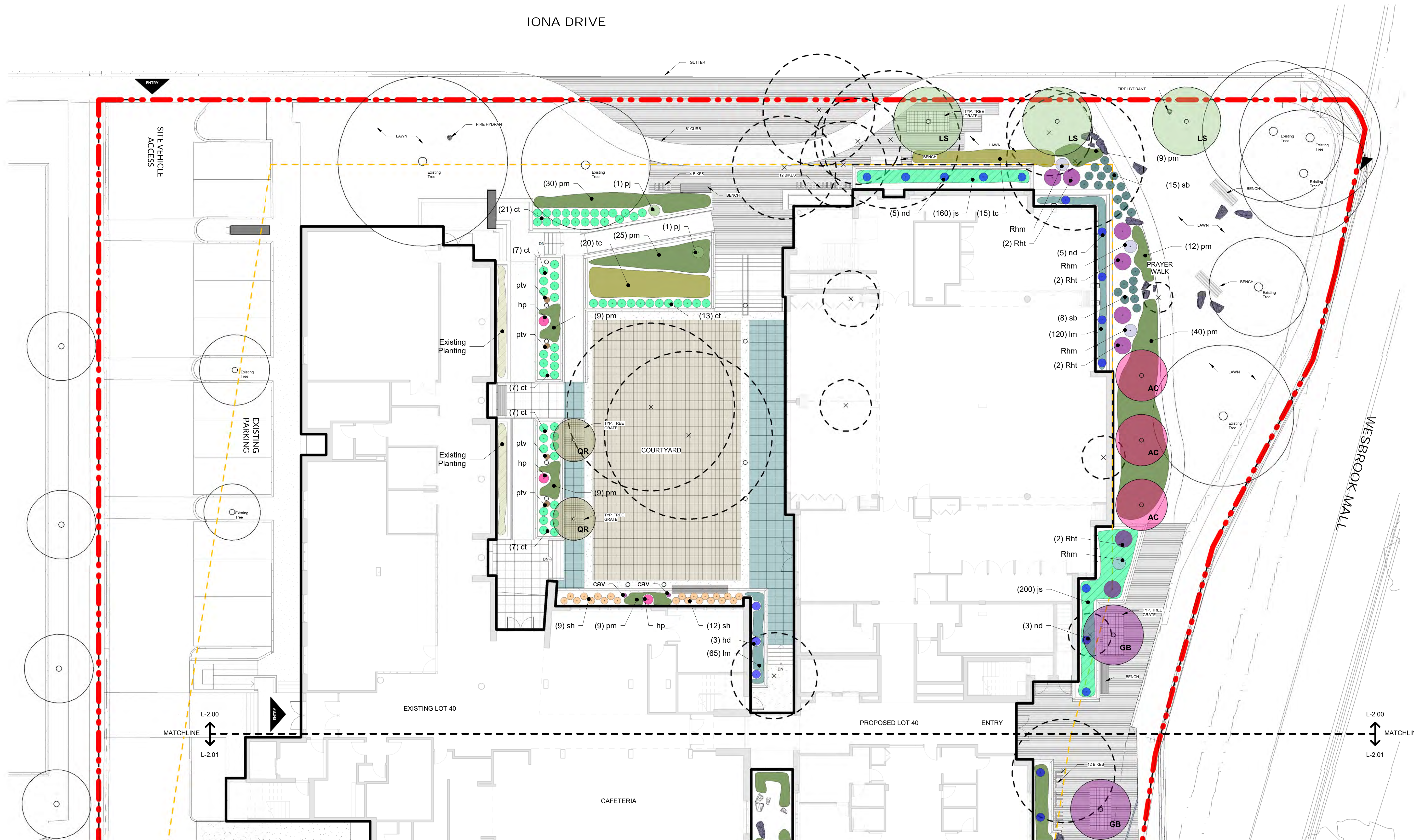

NOTES

- All landscape materials and installation to be in accordance with the Canadian Landscape Standard (latest edition).
- All plant material to be guaranteed for 1 year warranty period after approved final acceptance.
- All planting areas and planters to have an approved high efficiency automatic irrigation system to meet IIABC standards.
- Refer to Drawing L-2.2 for Plant List

1 Planting - North
3/32" = 1'-0"



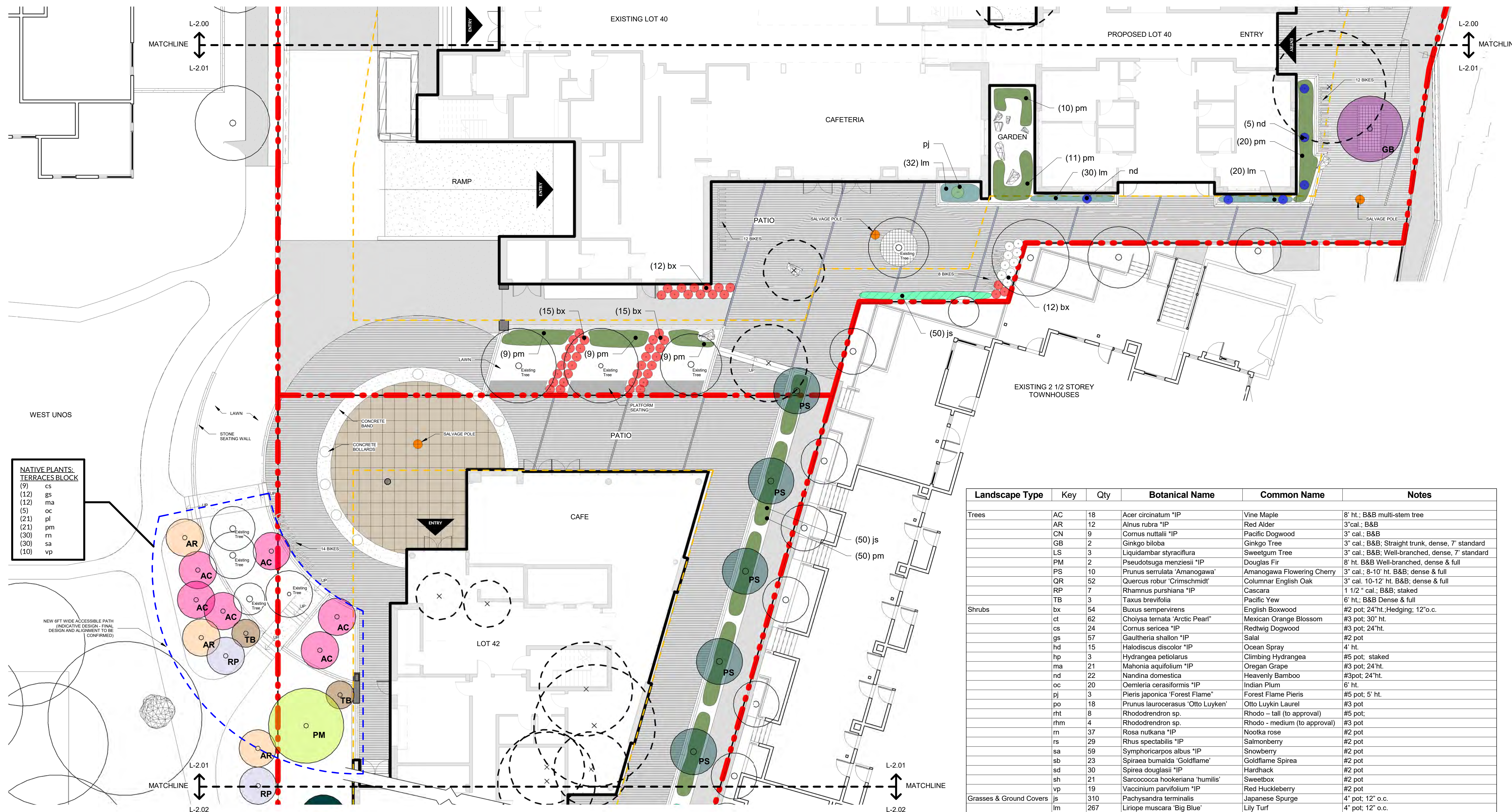

NATIVE PLANTS: TERRACES BLOCK

(9)	cs
(12)	gs
(12)	ma
(5)	oc
(21)	pl
(21)	pm
(30)	rn
(30)	sa
(10)	vp

Landscape Type	Key	Qty	Botanical Name	Common Name	Notes
Trees	AC	18	Acer circinatum *IP	Vine Maple	8' ht.; B&B multi-stem tree
	AR	12	Alnus rubra *IP	Red Alder	3' cal.; B&B
	CN	9	Cornus nuttallii *IP	Pacific Dogwood	3' cal.; B&B
	GB	2	Ginkgo biloba	Ginkgo Tree	3' cal.; B&B; Straight trunk, dense, 7' standard
	LS	3	Liquidambar styraciflura	Sweetgum Tree	3' cal.; B&B; Well-branched, dense, 7' standard
	PM	2	Pseudotsuga menziesii *IP	Douglas Fir	8' ht. B&B Well-branched, dense & full
	PS	10	Prunus serotina 'Amanogawa'	Amanogawa Flowering Cherry	3' cal.; 8-10' ht. B&B; dense & full
	QR	52	Quercus robur 'Crimschmidt'	Columnar English Oak	3' cal.; 10-12' ht. B&B; dense & full
	RP	7	Rhamnus purshiana *IP	Cascara	1 1/2" cal.; B&B; staked
	TB	3	Taxus brevifolia	Pacific Yew	6' ht.; B&B Dense & full
Shrubs	bx	54	Buxus sempervirens	English Boxwood	#2 pot; 24" ht.; Hedging; 12" o.c.
	ct	62	Choysa ternata 'Arctic Pearl'	Mexican Orange Blossom	#3 pot; 30" ht.
	cs	24	Cornus sericea *IP	Redtwig Dogwood	#3 pot; 24" ht.
	gs	57	Gaultheria shallon *IP	Salal	#2 pot
	hd	15	Halodiscus discolor *IP	Ocean Spray	4' ht.
	hp	3	Hydrangea petiolaris	Climbing Hydrangea	#5 pot; staked
	ma	21	Mahonia aquifolium *IP	Oregon Grape	#3 pot; 24" ht.
	nd	22	Nandina domestica	Heavenly Bamboo	#3pot; 24" ht.
	oc	20	Oemleria cerasiformis *IP	Indian Plum	6' ht.
	pj	3	Pieris japonica 'Forest Flame'	Forest Flame Pieris	#5 pot; 5' ht.
	po	18	Prunus laurocerasus 'Otto Luyken'	Otto Luykin Laurel	#3 pot
	rht	8	Rhododendron sp.	Rhodo - tall (to approval)	#5 pot;
	rhm	4	Rhododendron sp.	Rhodo - medium (to approval)	#3 pot;
	rn	37	Rosa nutkana *IP	Nootka rose	#2 pot
	rs	29	Rhus spectabilis *IP	Salmonberry	#2 pot
	sa	59	Symphoricarpos albus *IP	Snowberry	#2 pot
	sb	23	Spiraea bumalda 'Goldflame'	Goldflame Spirea	#2 pot
	sd	30	Spiraea douglasii *IP	Hardhack	#2 pot
	sh	21	Sarcococca hookeriana 'humilis'	Sweetbox	#2 pot
	vp	19	Vaccinium parvifolium *IP	Red Huckleberry	#2 pot
Grasses & Ground Covers	js	310	Pachysandra terminalis	Japanese Spurge	4' pot; 12" o.c.
	lm	267	Liriope muscarea 'Big Blue'	Lily Turf	4' pot; 12" o.c.
	ph	6	Phyllostachys nigra	Blackstem Bamboo	#3 pot; To approval
	pm	349	Polystichum munitum *IP	Sword Fern	#2 pot; 12" ht.
	tc	35	Taxus cuspidate nana	Spreading Japanese Yew	#2 pot
Climbing Vines	cav	2	Clematis armandii	Evergreen Clematis	#3 pot; 30" staked
	plv	4	Parthenocissus tricuspidata	Boston Ivy	#3 pot; 30" staked

*IP = Indigenous Plant

1 Planting - Centre (Mews)
3/32" = 1'-0"



NOTES

- All landscape materials and installation to be in accordance with the Canadian Landscape Standard (latest edition).
- All plant material to be guaranteed for 1 year warranty period after approved final acceptance.
- All planting areas and planters to have an approved high efficiency automatic irrigation system to meet IIABC standards.
- Refer to Drawing L-2.2 for Plant List

2	Issue for DP	2022.01.07
1	Development Application AUDP	2022.01.04
No.	Description	Date

SEAL:

PROJECT:

Carey Theological College

LOT 40 & LOT 42
5920 Iona Drive
Vancouver, BC

PROJECT NO.: DP 2022 0104

CONSULTANTS:

DRAWN BY:

MRM

FILE NO.:

2021.01.04

DATE:

3/32" = 1'-0"

SCALE:

TITLE:

Landscape Planting Plan - Central

SHEET NO.:

REVISION:

L-2.01

2



No.	Description	Date
2	Issue for DP	2022.01.07
1	Development Application AUDP	2022.01.04

PROJECT:
Carey Theological College
LOT 40 & LOT 42
5920 Iona Drive
Vancouver, BC

PROJECT NO.: DP 2022 0104

CONSULTANTS:

DRAWN BY:
MRM

DATE:
2021.01.04

SCALE:
3/32" = 1'-0"

TITLE:
Landscape Planting Plan - South

SHEET NO.: REVISION:

L-2.02 **2**

1 Planting - South (Gage)
3/32" = 1'-0"



NOTES

- All landscape materials and installation to be in accordance with the Canadian Landscape Standard (latest edition).
- All plant material to be guaranteed for 1 year warranty period after approved final acceptance.
- All planting areas and planters to have an approved high efficiency automatic irrigation system to meet IIABC standards.
- Refer to Drawing L-2.2 for Plant List

No.	Description	Date
2	Issue for DP	2022.01.07
1	Development Application AUDP	2022.01.04

PROJECT:

Carey Theological College
LOT 40 & LOT 42
5920 Iona Drive
Vancouver, BC

PROJECT NO.: DP 2022 0104

CONSULTANTS:

DRAWN BY:

MRM

FILE NO.:

2021.01.04

DATE:

3/32" = 1'-0"

SCALE:

Landscape Planting Plan - Roof North

TITLE:

SHEET NO.:

L-2.03

REVISION:

2

1 Planting Roof - North
3/32" = 1'-0"

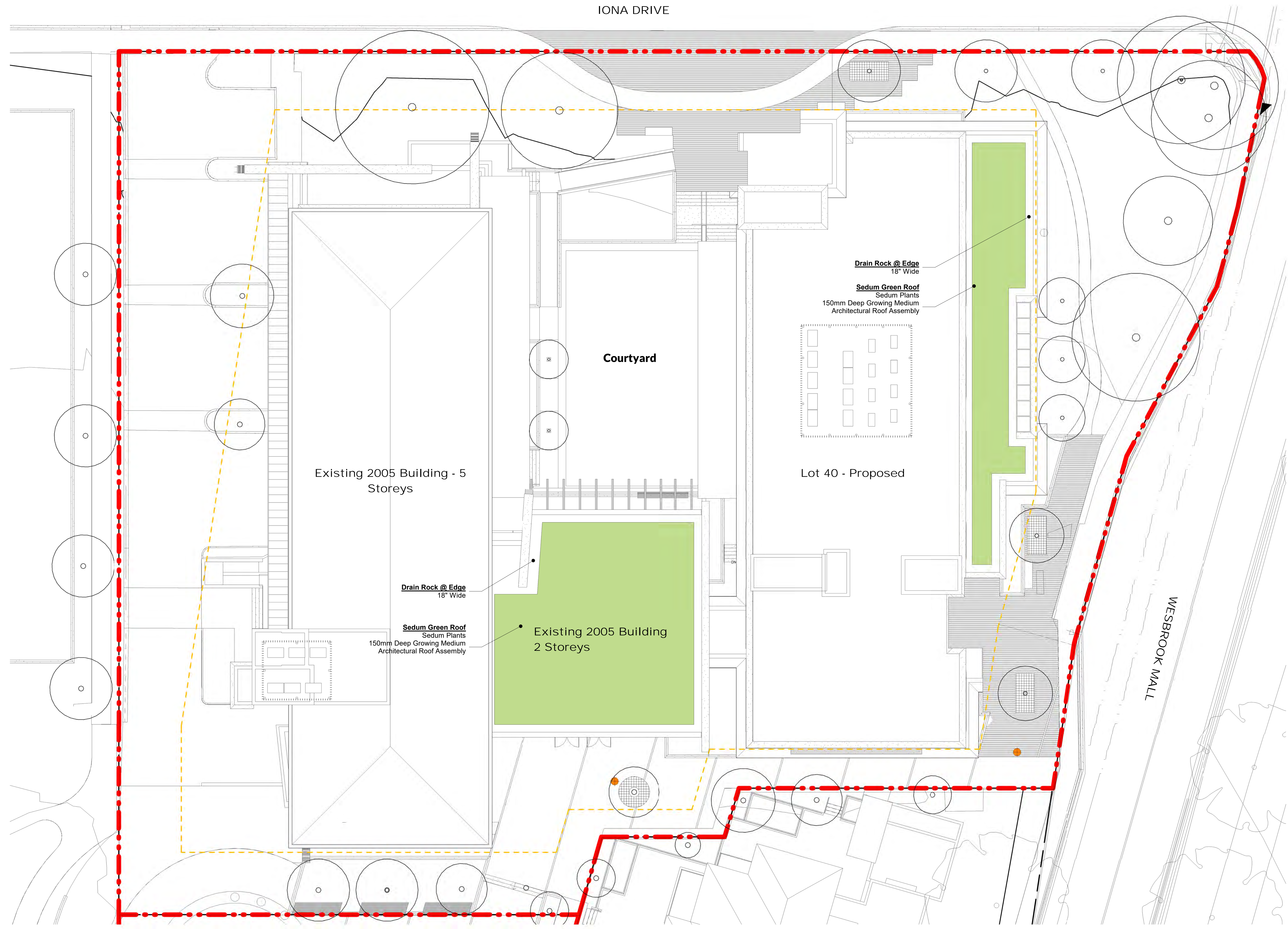

No.	Description	Date
2	Issue for DP	2022.01.07
1	Development Application AUDP	2022.01.04

PROJECT:
Carey Theological College
LOT 40 & LOT 42
5920 Iona Drive
Vancouver, BC

PROJECT NO.: DP 2022 0104

CONSULTANTS:

DRAWN BY:
MRM

FILE NO.:

DATE:
2021.01.04

SCALE:
3/32" = 1'-0"

TITLE:
Landscape Planting Plan - Roof South

SHEET NO.: REVISION:

L-2.04 **2**

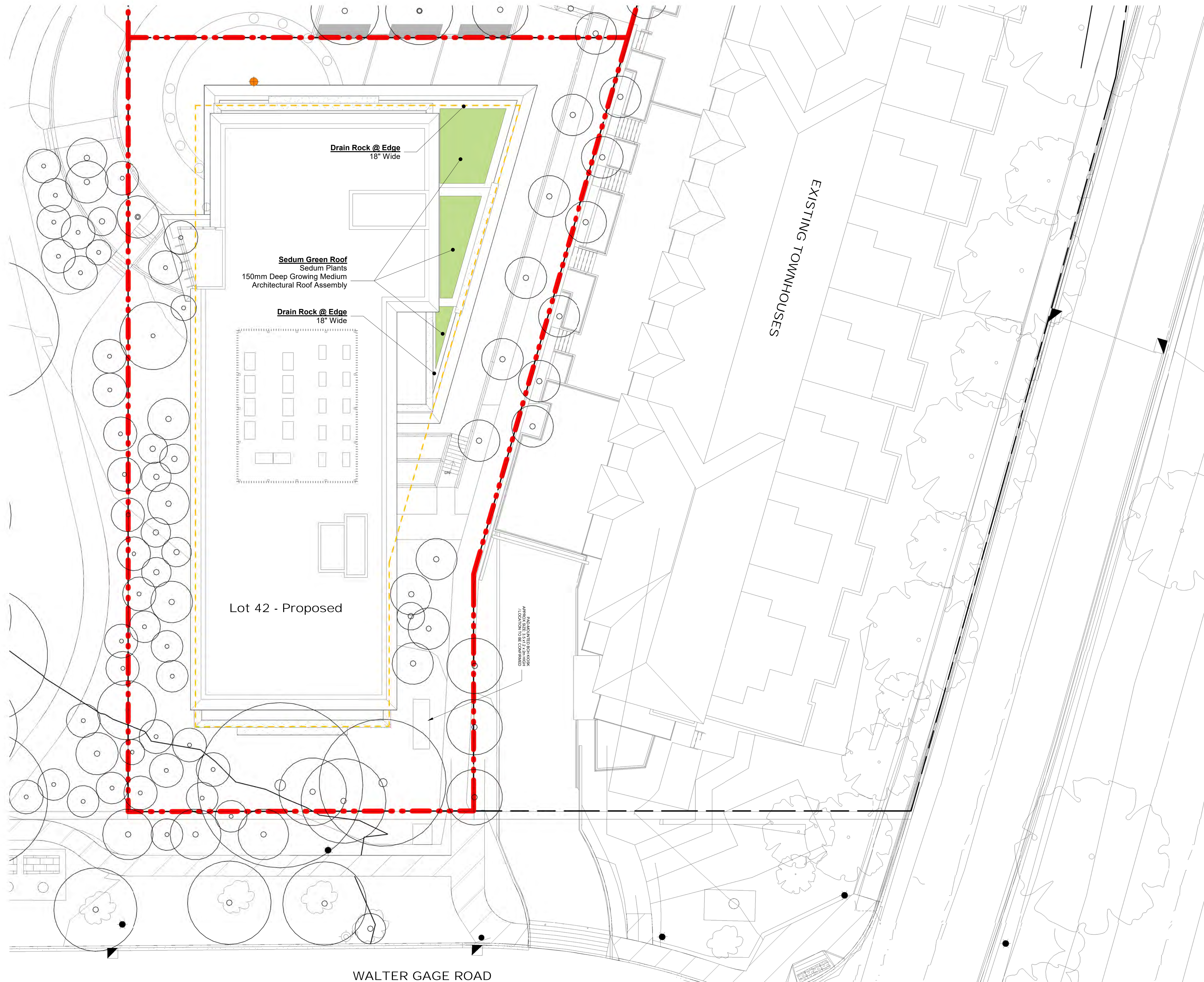

1 **Planting Roof - South**
3/32" = 1'-0"



WALTER GAGE ROAD

EXISTING TOWNHOUSES

Lot 42 - Proposed

APPROXIMATE ROCK BED
LOCATION TO BE CONFIRMED

2	Issue for DP	2022.01.07
1	Development Application AUDP	2022.01.04
No.	Description	Date
SEAL:		

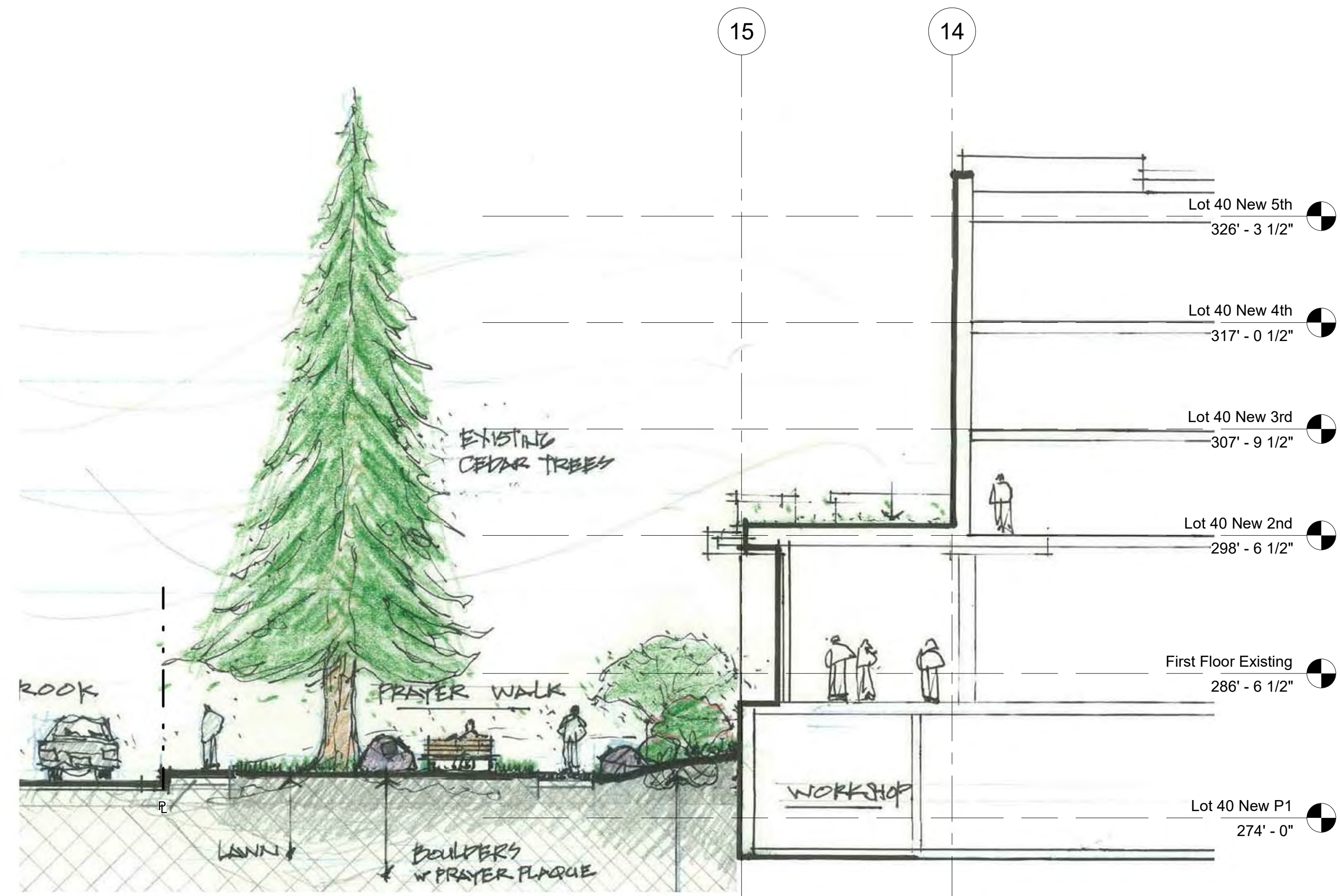

1 Landscape Section - Wesbrook
1/8" = 1'-0"

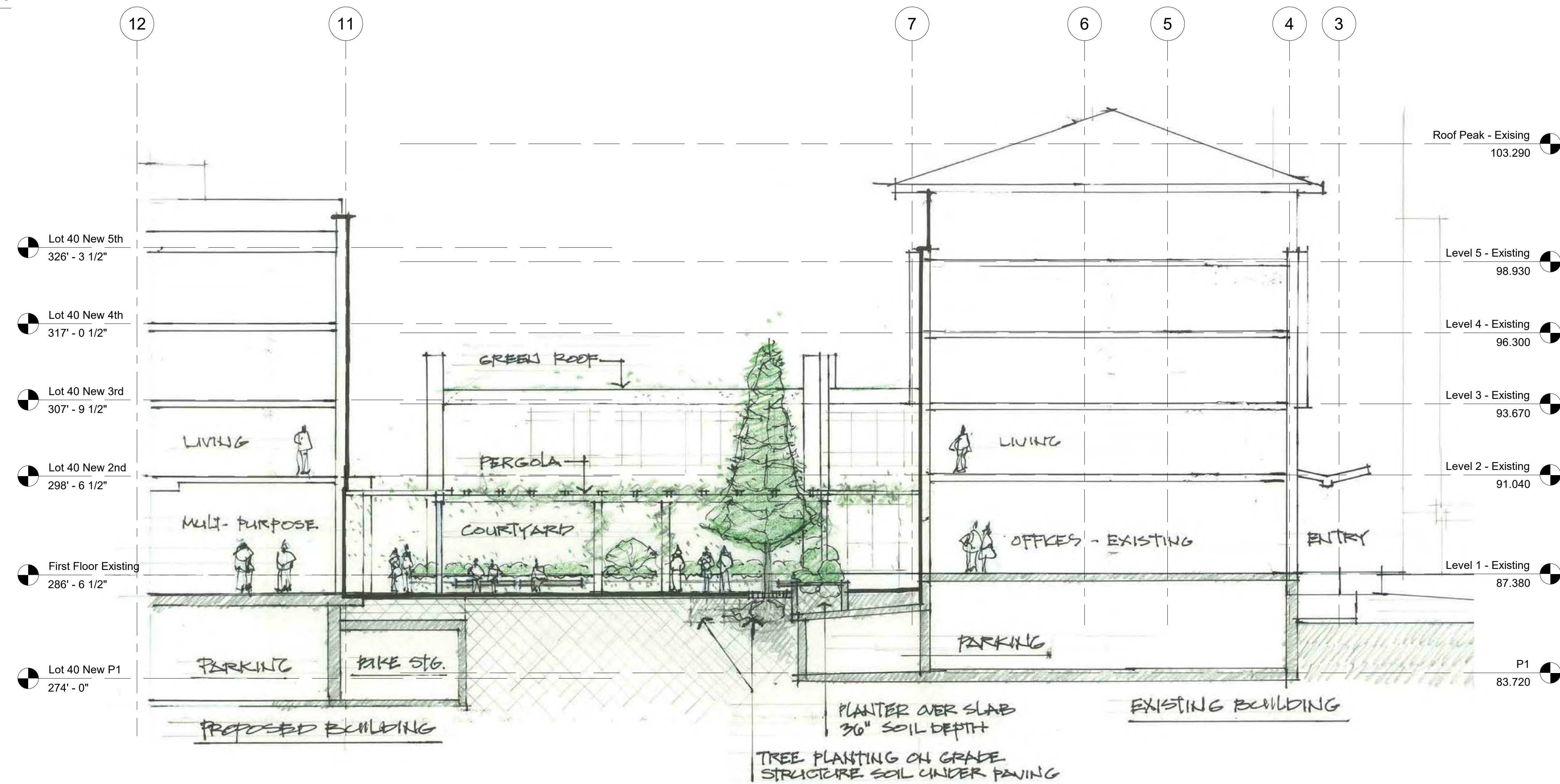

2 Landscape Section - Courtyard
1/8" = 1'-0"

PROJECT:
Carey Theological College
LOT 40 & LOT 42
5920 Iona Drive
Vancouver, BC

PROJECT NO.: DP 2022 0104

CONSULTANTS:

DRAWN BY:
MRM

FILE NO.:

DATE:
2021.01.04

SCALE:
1/8" = 1'-0"

TITLE:
Landscape - Sections

SHEET NO.: REVISION:

L-3.00 2

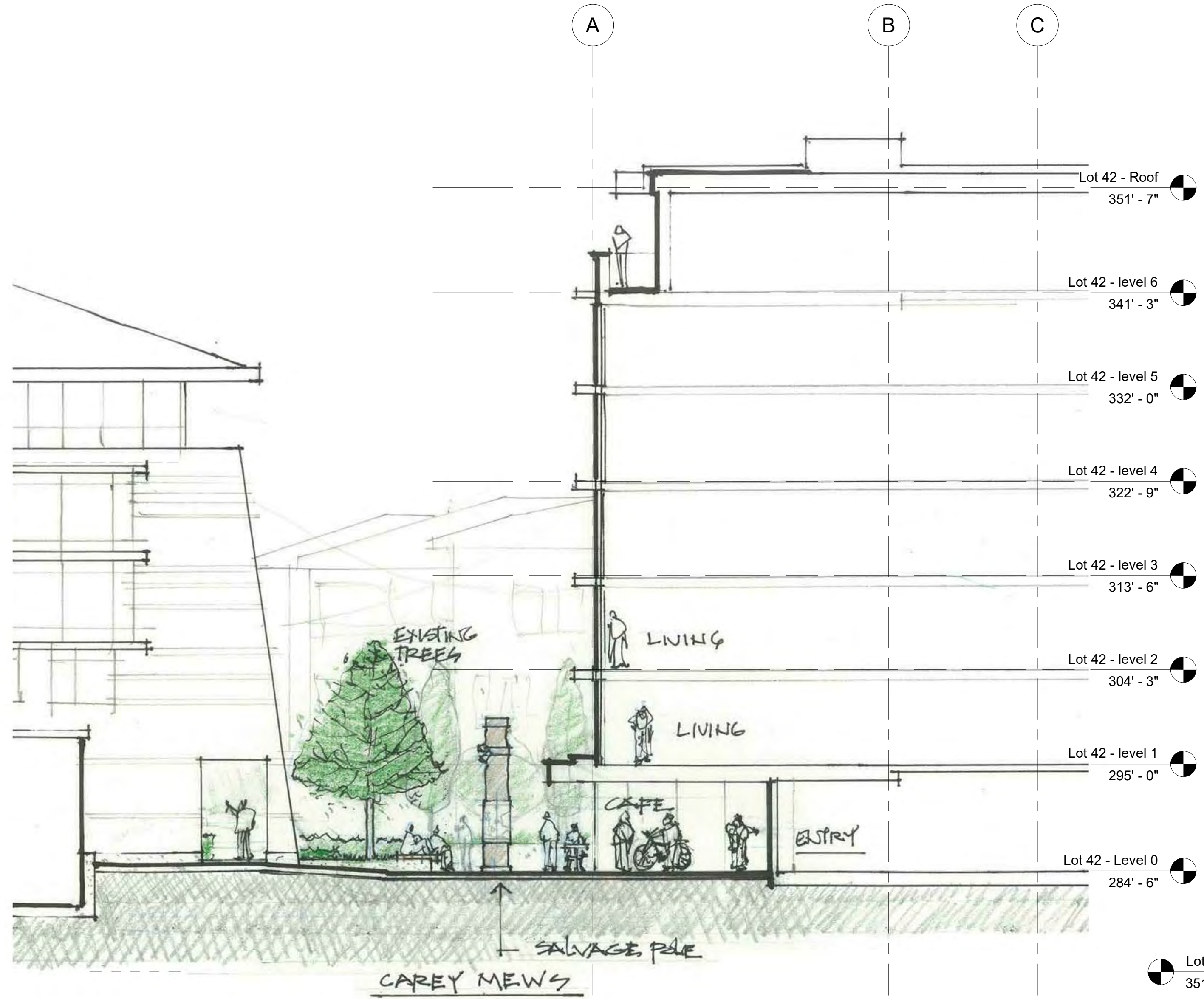

1 Landscape Section - Mews
1/8" = 1'-0"

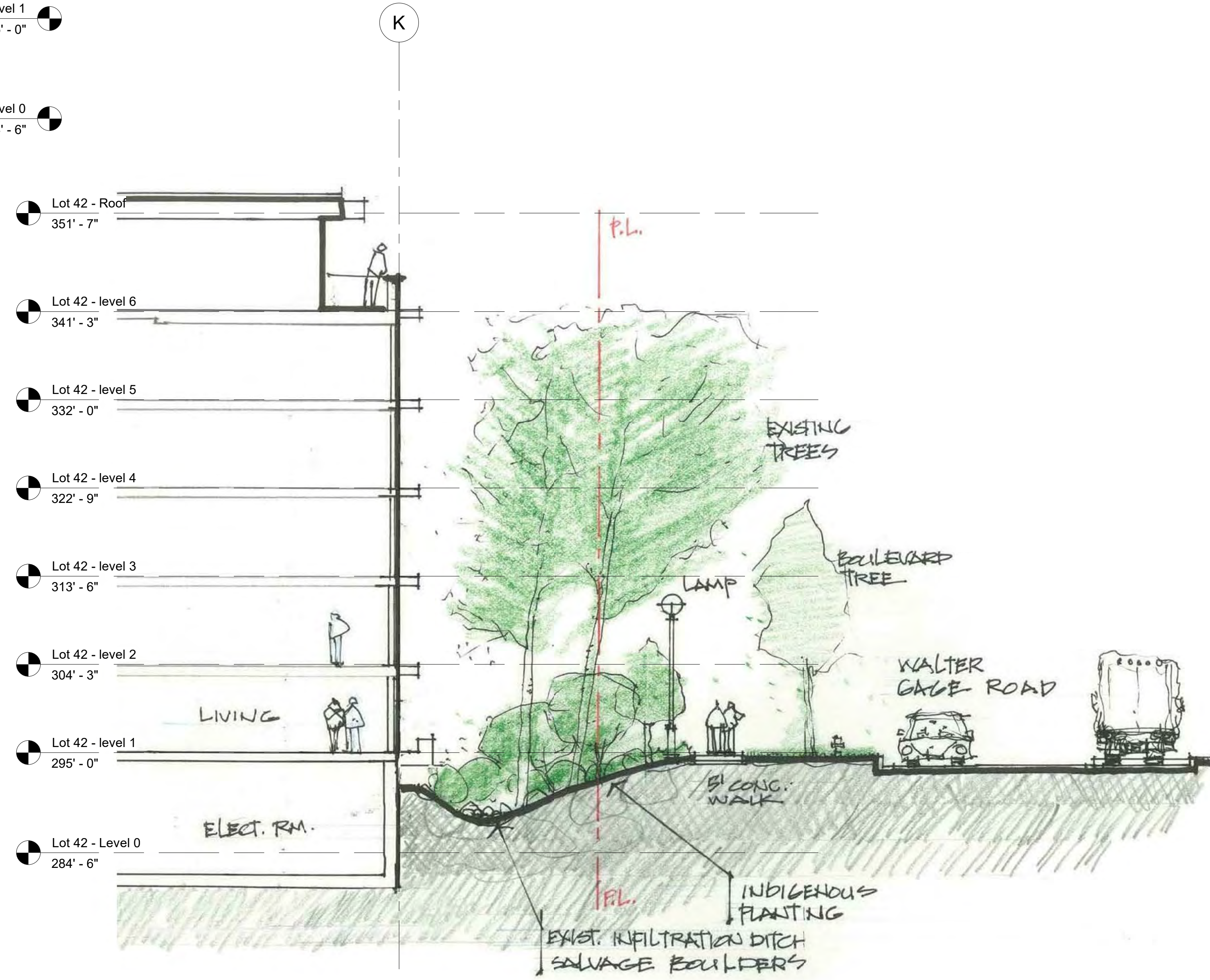

2 Landscape Section - Gage
1/8" = 1'-0"

No.	Description	Date
2	Issue for DP	2022.01.07
1	Development Application AUDP	2022.01.04

PROJECT:
Carey Theological College
LOT 40 & LOT 42
5920 Iona Drive
Vancouver, BC
PROJECT NO.: DP 2022 0104
CONSULTANTS:

DRAWN BY:
MRM
FILE NO.:
DATE:
2021.01.04
SCALE:
1/8" = 1'-0"
TITLE:
Landscape - Sections
SHEET NO.:
REVISION:

No.	Description	Date
2	Issue for DP	2022.01.07
1	Development Application AUDP	2022.01.04

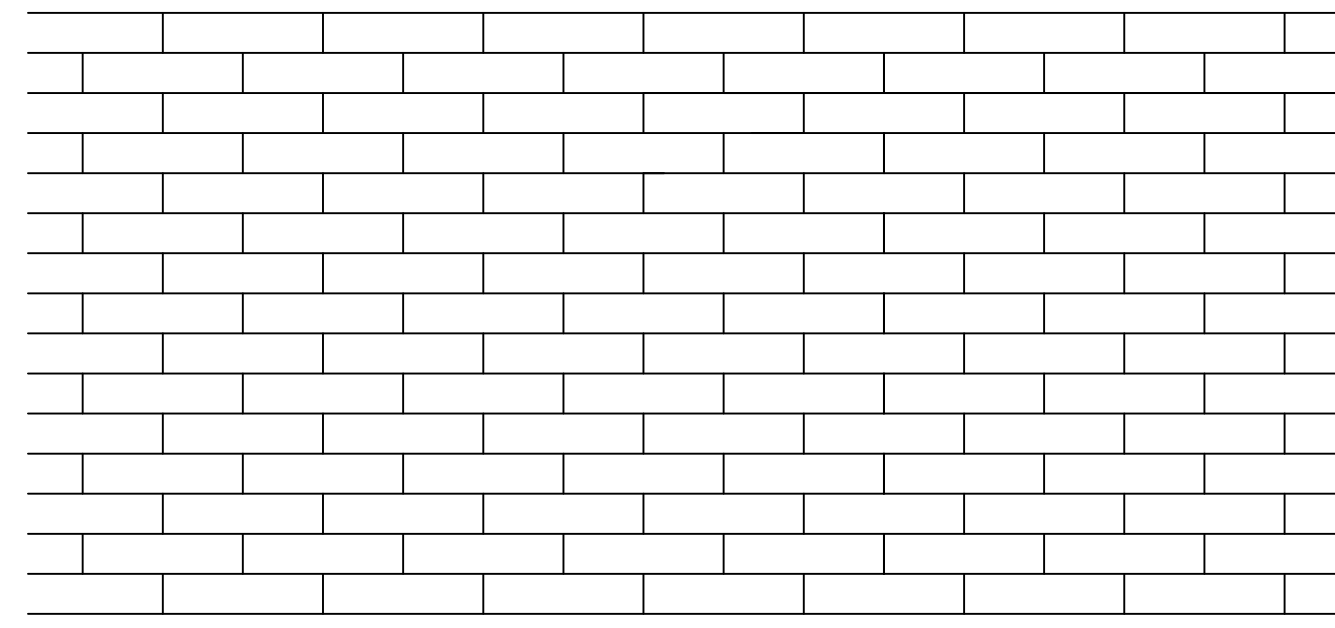

Natural

FIELD

CONCRETE UNIT PAVING:

Type: Broadway Plank Series Paving Pattern: Running Bond
Size: 24" x 6" x 4" thk.
Colour: Natural (as main field)
Manufacturer: Barkman Concrete
Website: www.barkmanconcrete.com
Phone: 1-800-461-2278

1 Concrete Unit Paving
NTS



OUTDOOR PORCELAIN TILE:

Type: Landstone Outdoor
Size: 12" x 24" x 2cm thk.
Colour: Sand
Manufacturer: BC Brick
Website: www.bcbbrick.com
Phone: 1-604-270-1947

4 Porcelain Tile
NTS

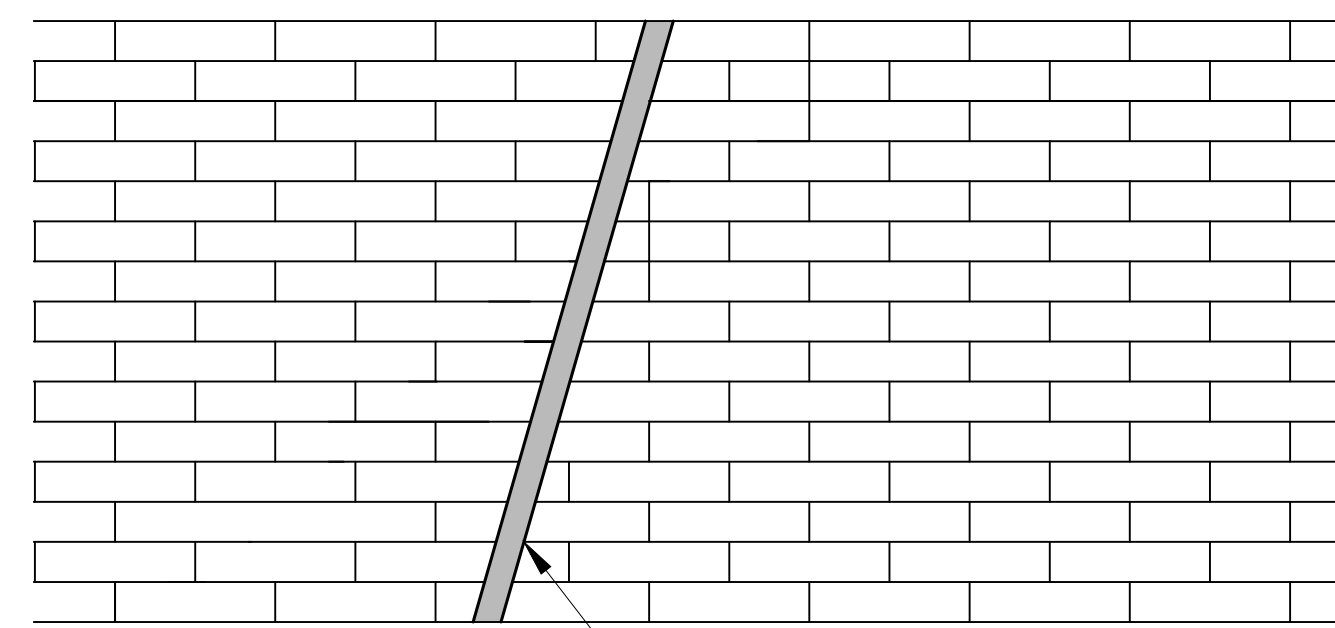

GRANITE ACCENT:
4'L x 4"W x 4"D



Charcoal

ACCENT

CONCRETE UNIT PAVING:

Type: Broadway Plank Series Paving Pattern: Running Bond
Size: 24" x 6" x 4" thk.
Colour: Charcoal (as random accents)
Manufacturer: Barkman Concrete
Website: www.barkmanconcrete.com
Phone: 1-800-461-2278

2 Concrete Unit Paving
NTS

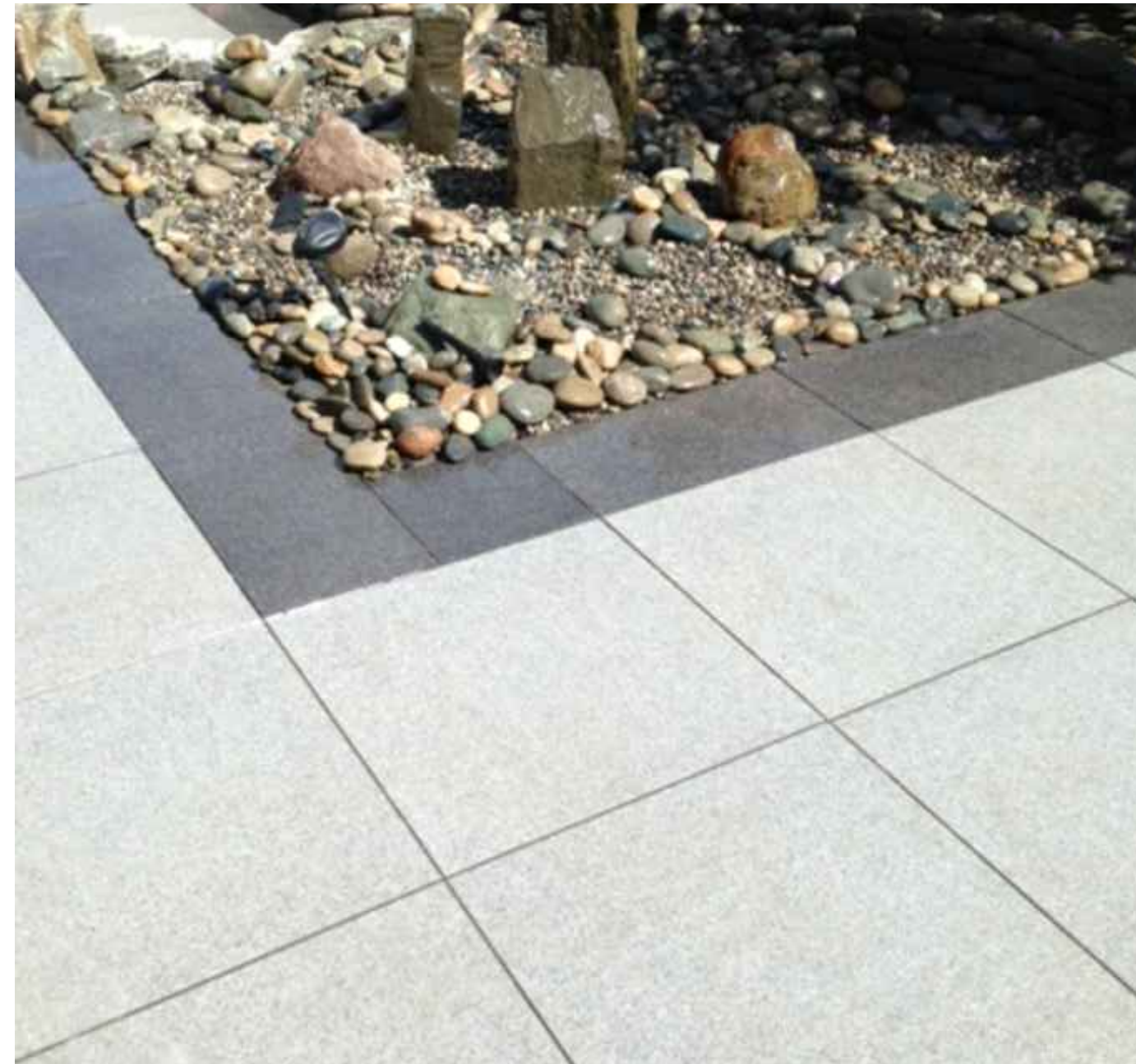

OUTDOOR PORCELAIN TILE:

Type: Landstone Outdoor
Size: 24" x 24" x 2cm thk.
Colour: Granite
Manufacturer: BC Brick
Website: www.bcbbrick.com
Phone: 1-604-270-1947

5 Porcelain Tile
NTS

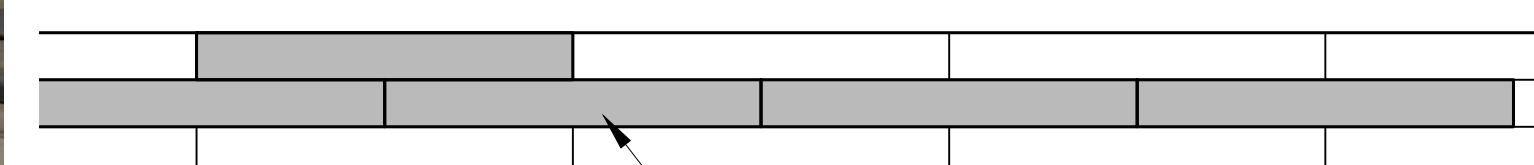
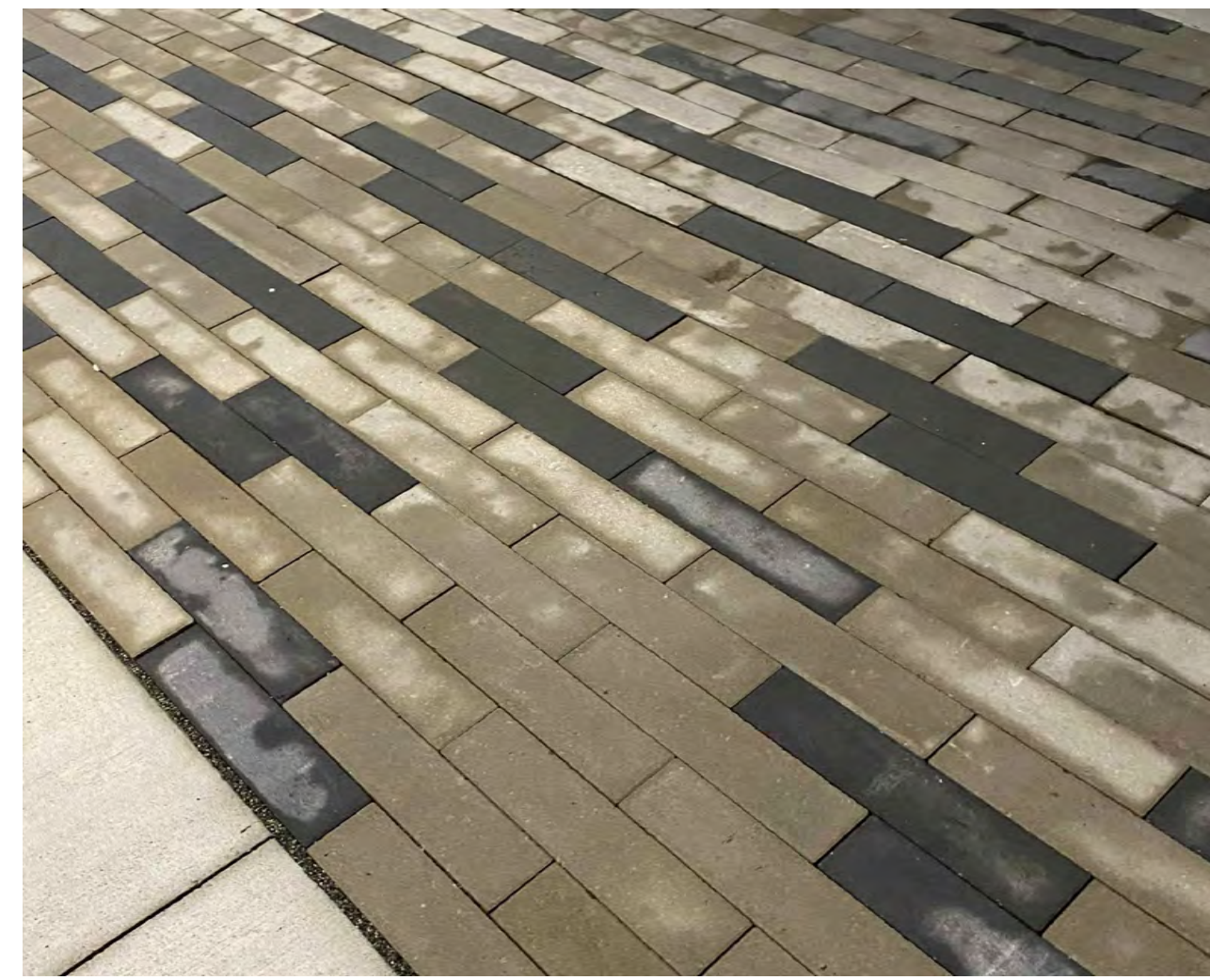

Pattern 1 TYP. CHARCOAL ACCENT:
24"Lx 6"W x 4"D

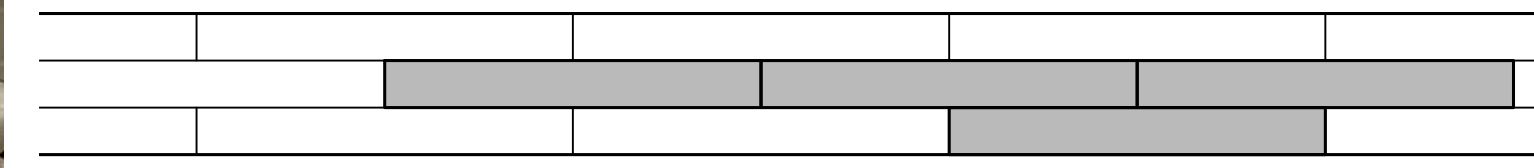

Pattern 2

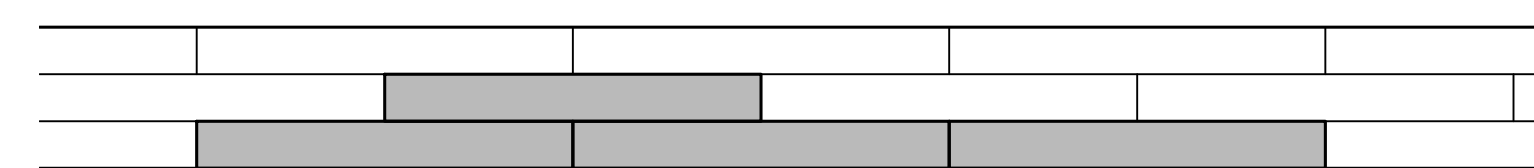

Pattern 3

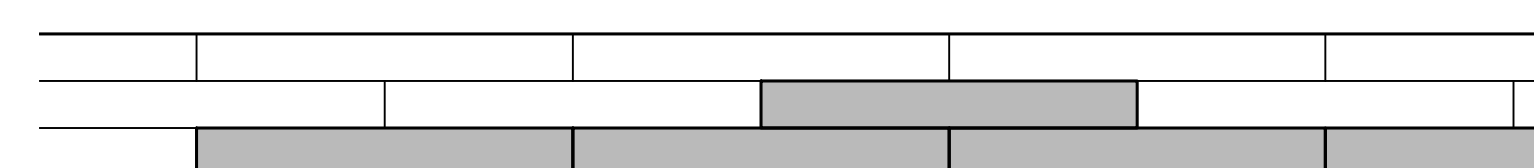

Pattern 4



3 Concrete Unit Paving Patterns
NTS

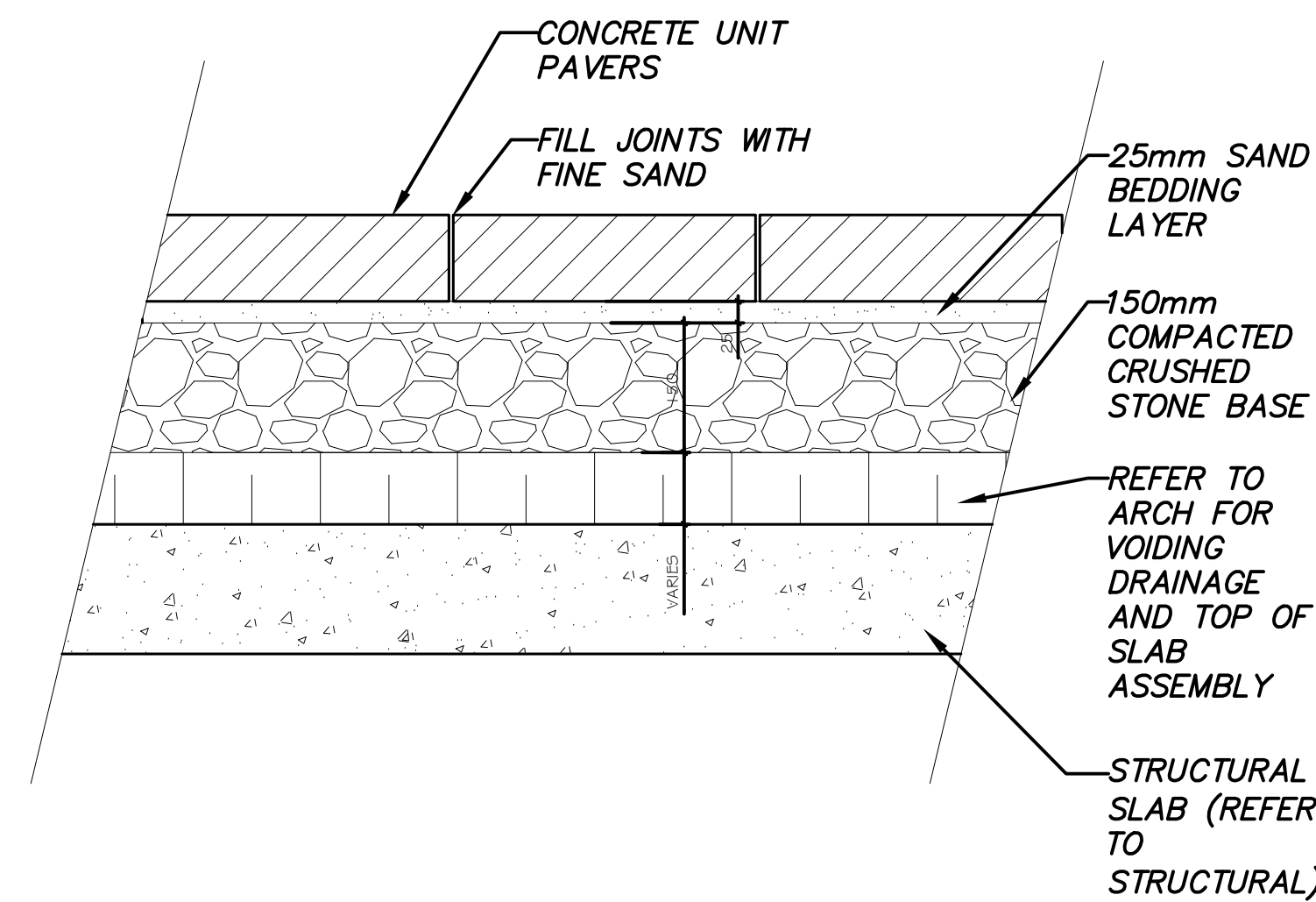

6 Concrete Unit Paving on Slab
1-1/2" = 1'-0"

PROJECT:

Carey Theological College
LOT 40 & LOT 42
5920 Iona Drive
Vancouver, BC

PROJECT NO.: DP 2022 0104

CONSULTANTS:

DRAWN BY:

KY

FILE NO.:

DATE:

2022.01.04

SCALE:

Varies

TITLE:

Landscape - Details

SHEET NO.: REVISION:

L-4.00

Copyright reserved

Everything shown hereon for use on this project only and may not be reproduced without the Architect's written permission and unless the reproduction carries their name.

2	Issue for DP	2022.01.07
1	Development Application AUDP	2022.01.04
No.	Description	Date

SEAL:



BENCHES:

Type: Neoliviano Bench
Size: 69" - 118" Length Varies
Colour: Aluminum Grey
Manufacturer: Landscape Forms
Website: www.landscapeforms.com
Phone: 1-800-430-6209

① Amenity Level Bench
NTS



BOLLARD

Type: Class Bollard #8-2C1
Size: 8" Dia., 36" H
Colour: Aluminum
Manufacturer: Urban Accessories
Website: www.urbanaccessories.com
Phone: 1-800-667-8141

② Bollards
NTS



BIKE RACK

Type: Curves
Size: 3-1/2" W x 24" L x 30" H
Colour: Aluminum Brushed
Manufacturer: Urban Accessories
Website: www.urbanaccessories.com
Phone: 1-800-667-8141

③ Bike Rack
NTS



BOLLARD LIGHT
Type A: Bollard DG-2
Option: 5W LED
Size: 8" Dia., x 36" H
Colour: Aluminum Brushed
Manufacturer: Urban Accessories
Website: www.urbanaccessories.com
Phone: 1-800-667-8141



RECESSED WALL LIGHT
Type B: BEGA 33.053 LED

④ Landscape Lighting
NTS

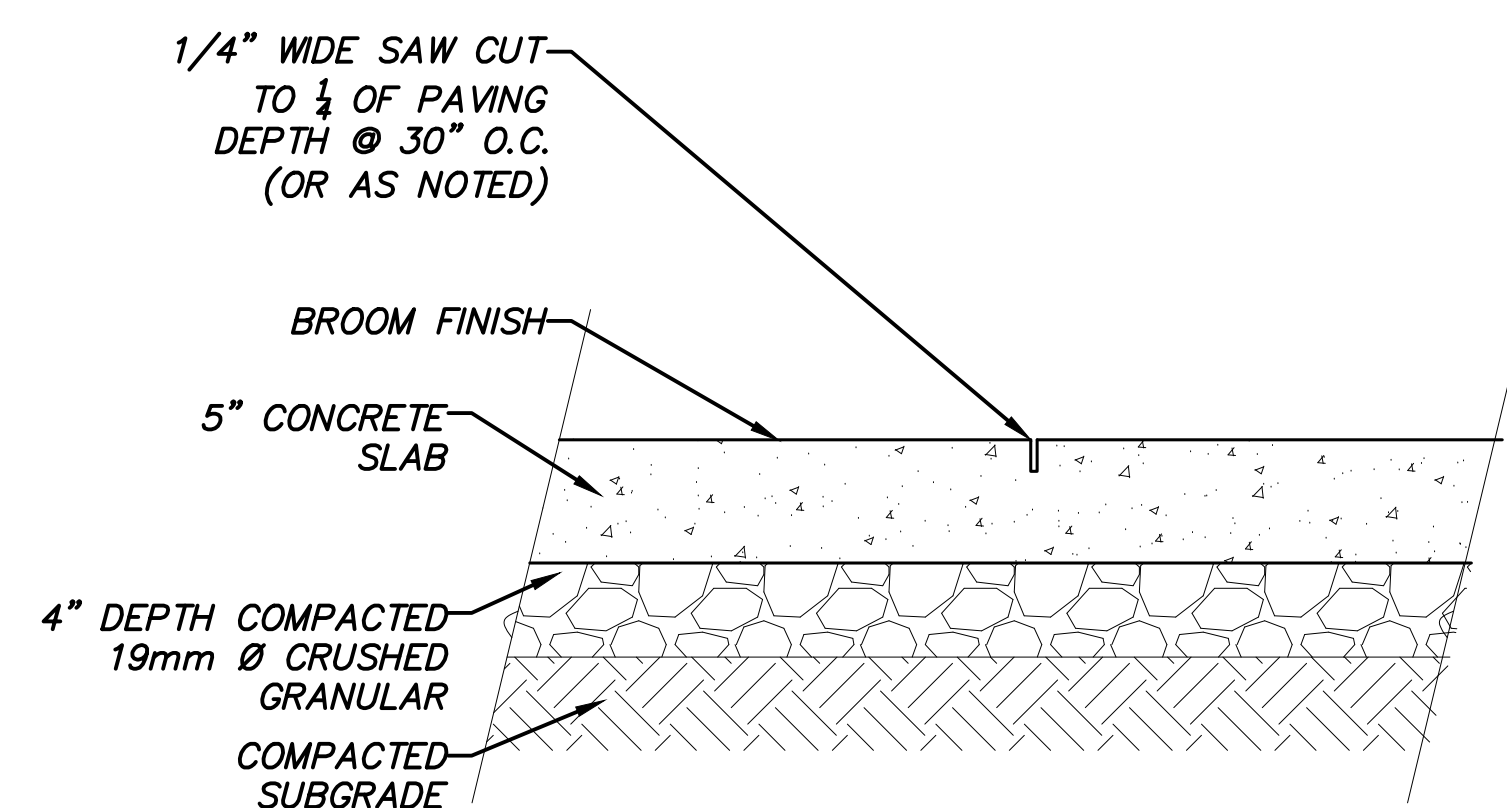

⑤ Concrete Paving on Grade - Pedestrian
1-1/2" = 1'-0"

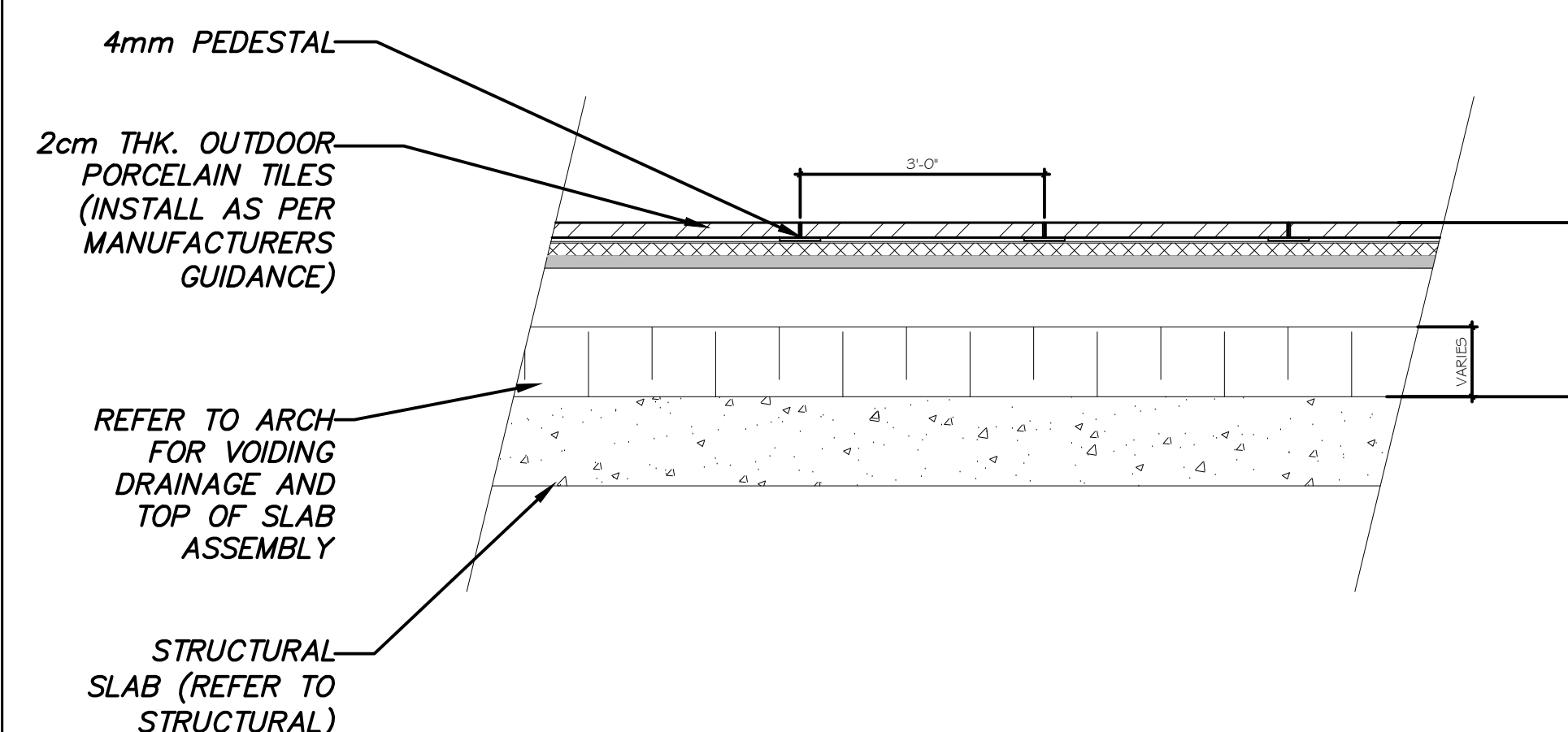

⑥ Porcelain Tile on Slab
1-1/2" = 1'-0"

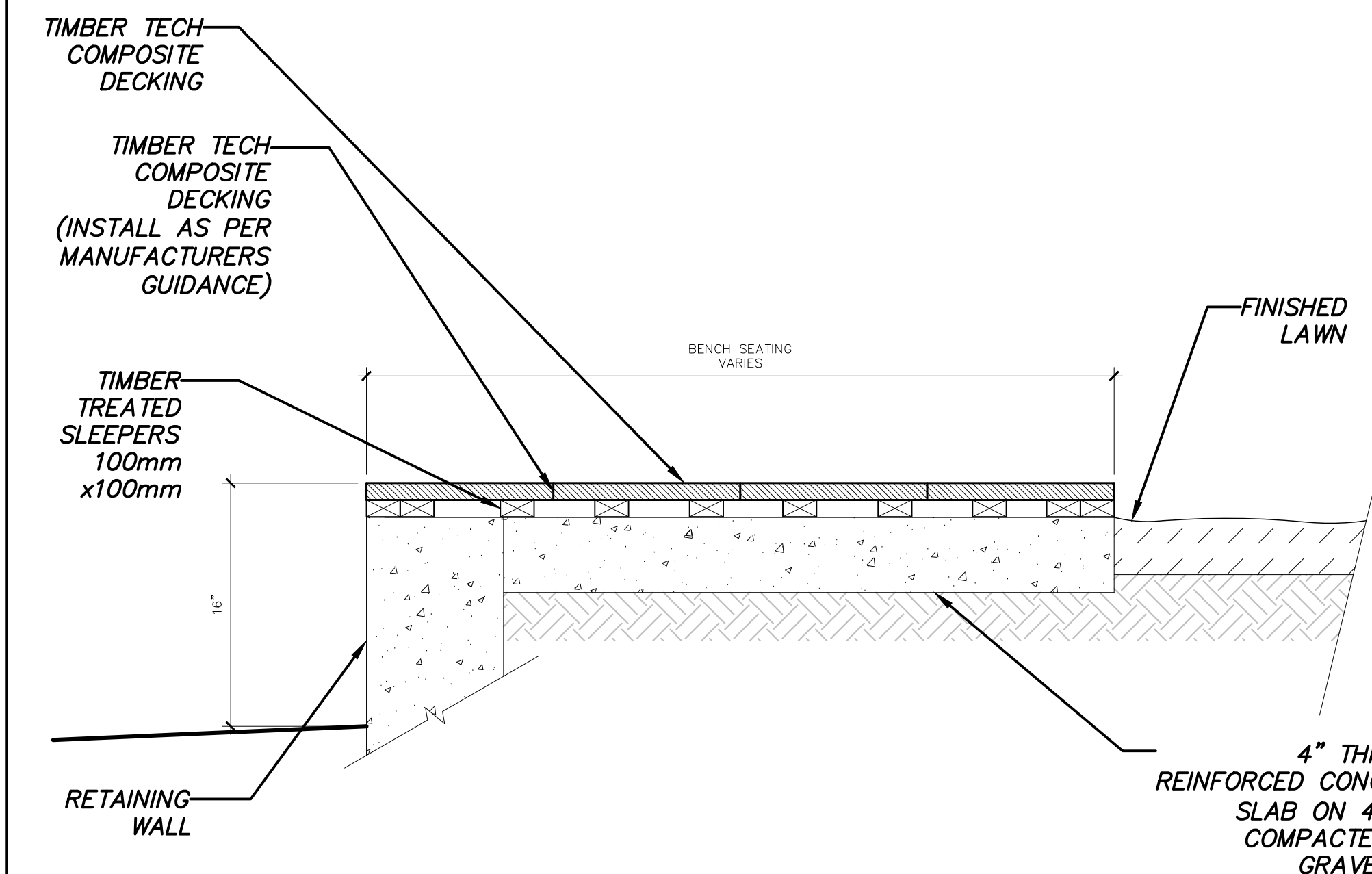

⑦ Composite Wood Bench
1-1/2" = 1'-0"

PROJECT:

Carey Theological College
LOT 40 & LOT 42
5920 Iona Drive
Vancouver, BC

PROJECT NO.: DP 2022 0104

CONSULTANTS:

DRAWN BY:

KY

FILE NO.:

DATE:

2022.01.04

SCALE:

Varies

TITLE:

Landscape - Details

SHEET NO.:

REVISION:

L-4.01

Copyright reserved
Everything shown hereon for use on this project only and may not be reproduced without the Architect's written permission and unless the reproduction carries their name.

2	Issue for DP	2022.01.07
1	Development Application AUDP	2022.01.04
No.	Description	Date

SEAL:

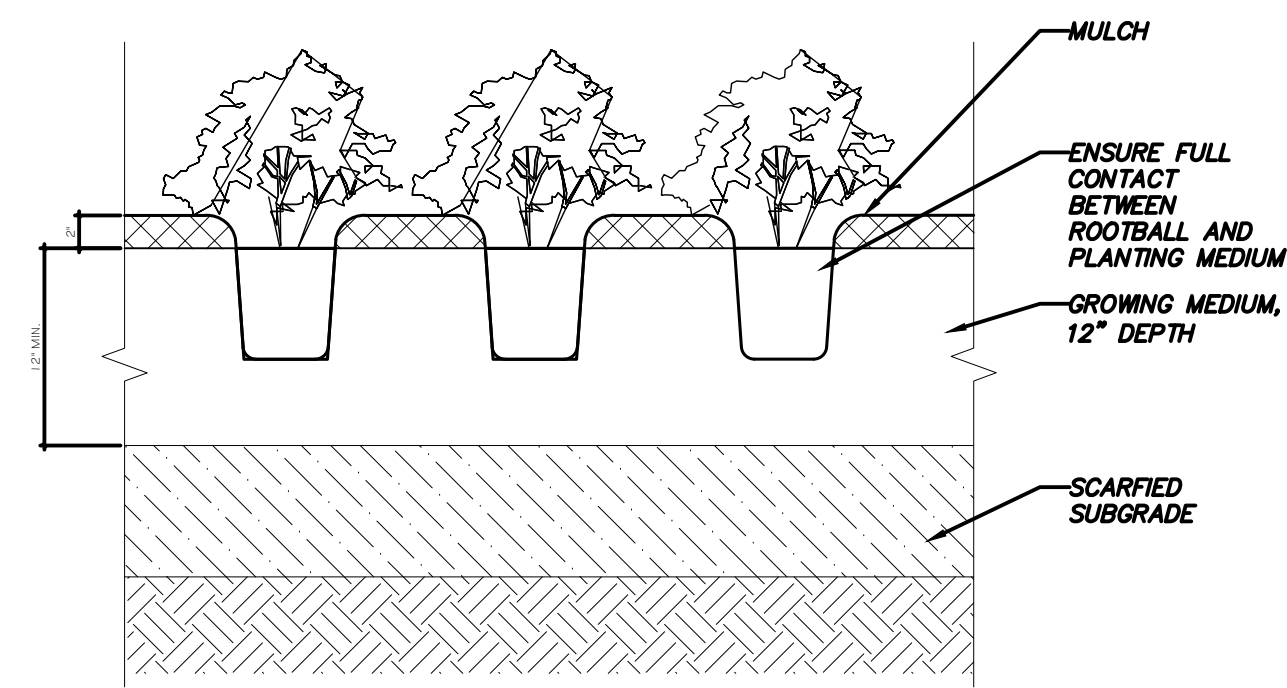

1 Typical Ground Cover
1" = 1'-0"

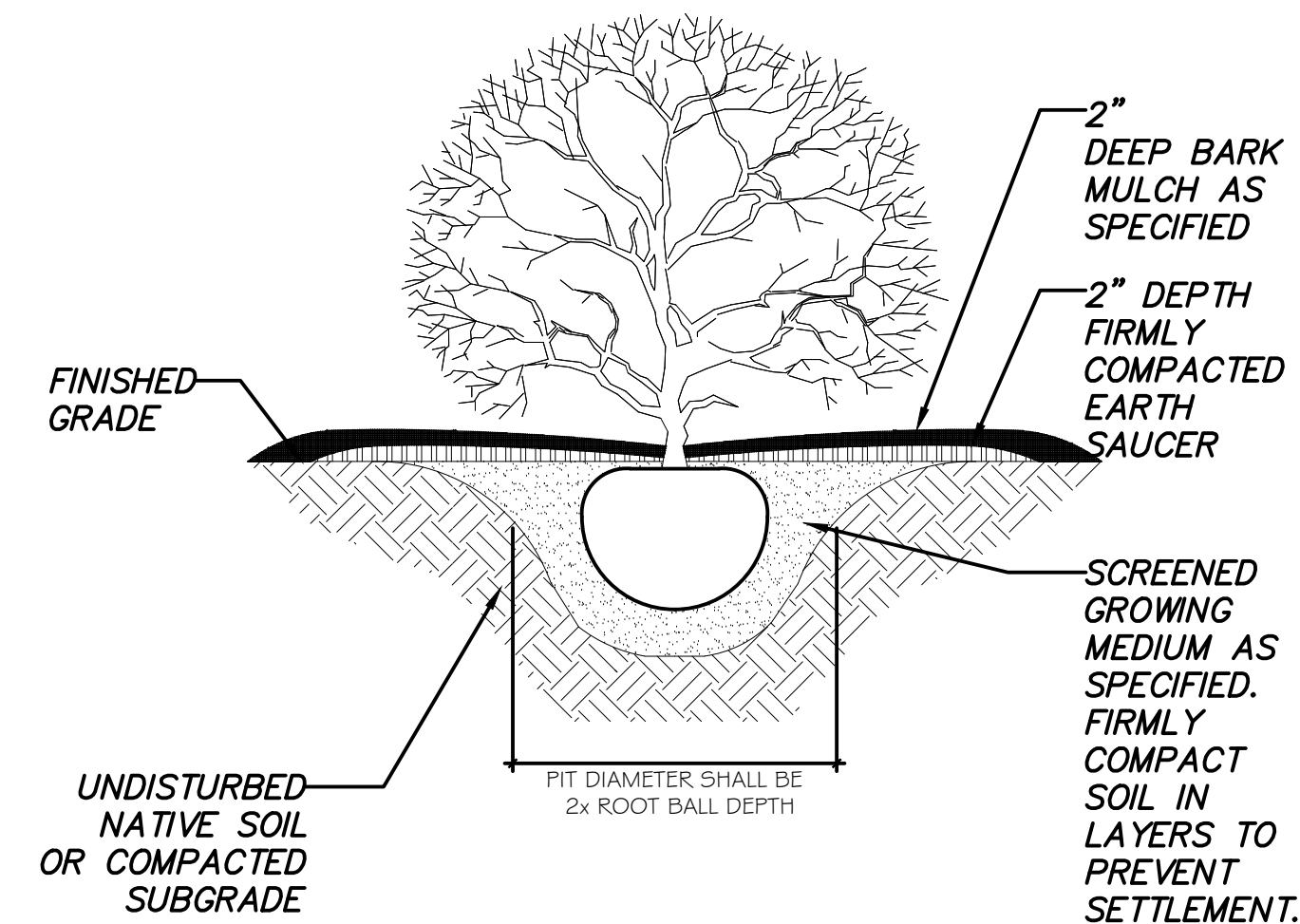

2 Typical Shrub
1/2" = 1'-0"

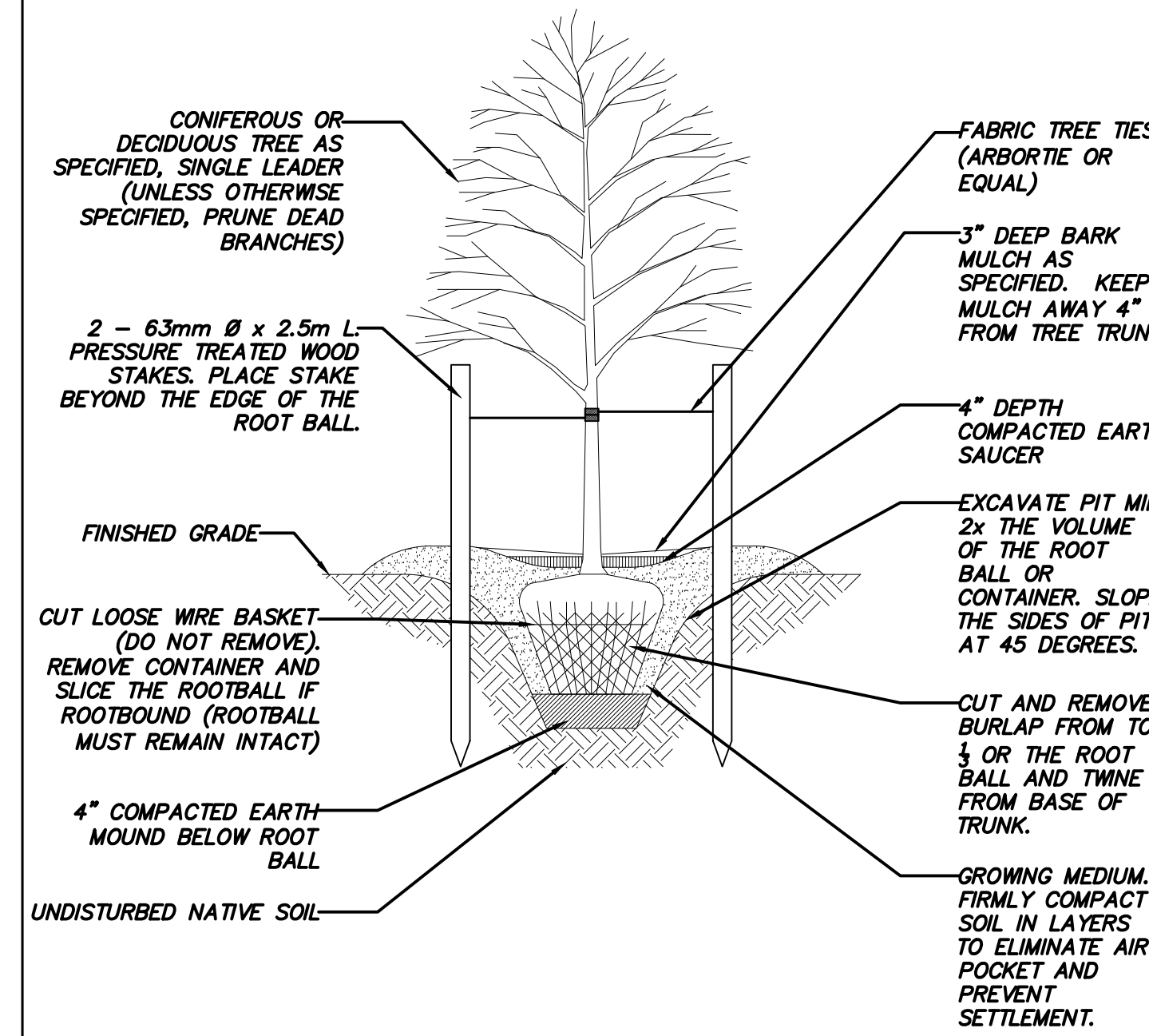

3 Typical Tree on Grade
1" = 1'-0"

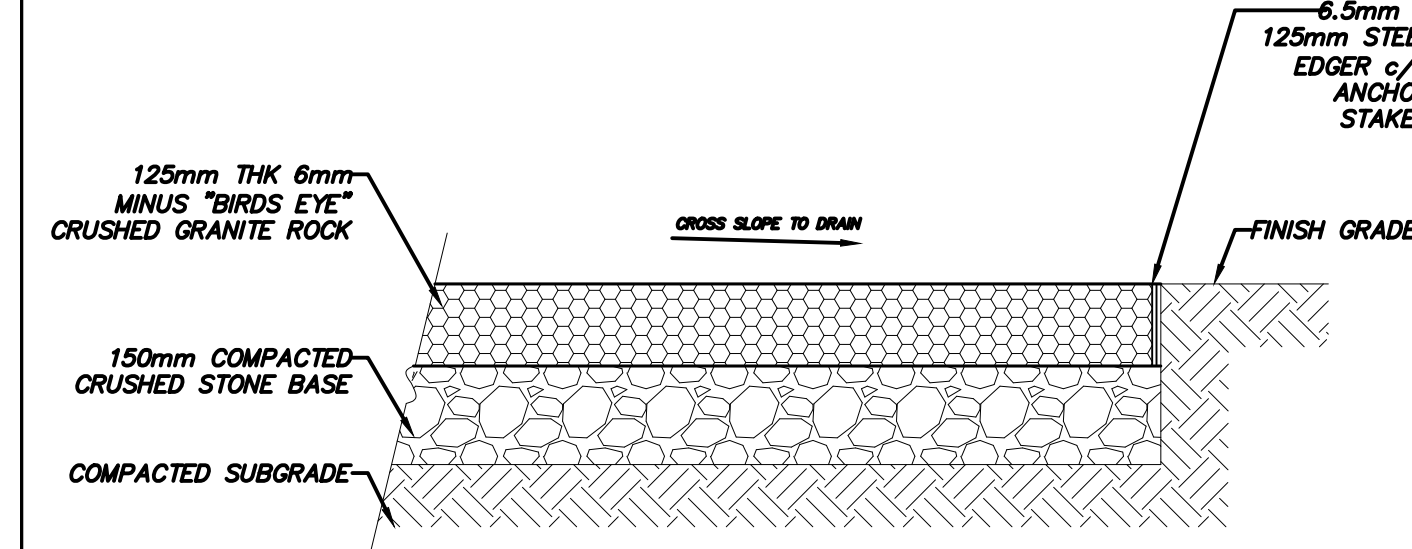

4 Crushed Granite Rock on Grade
1'-0" = 1'-0"

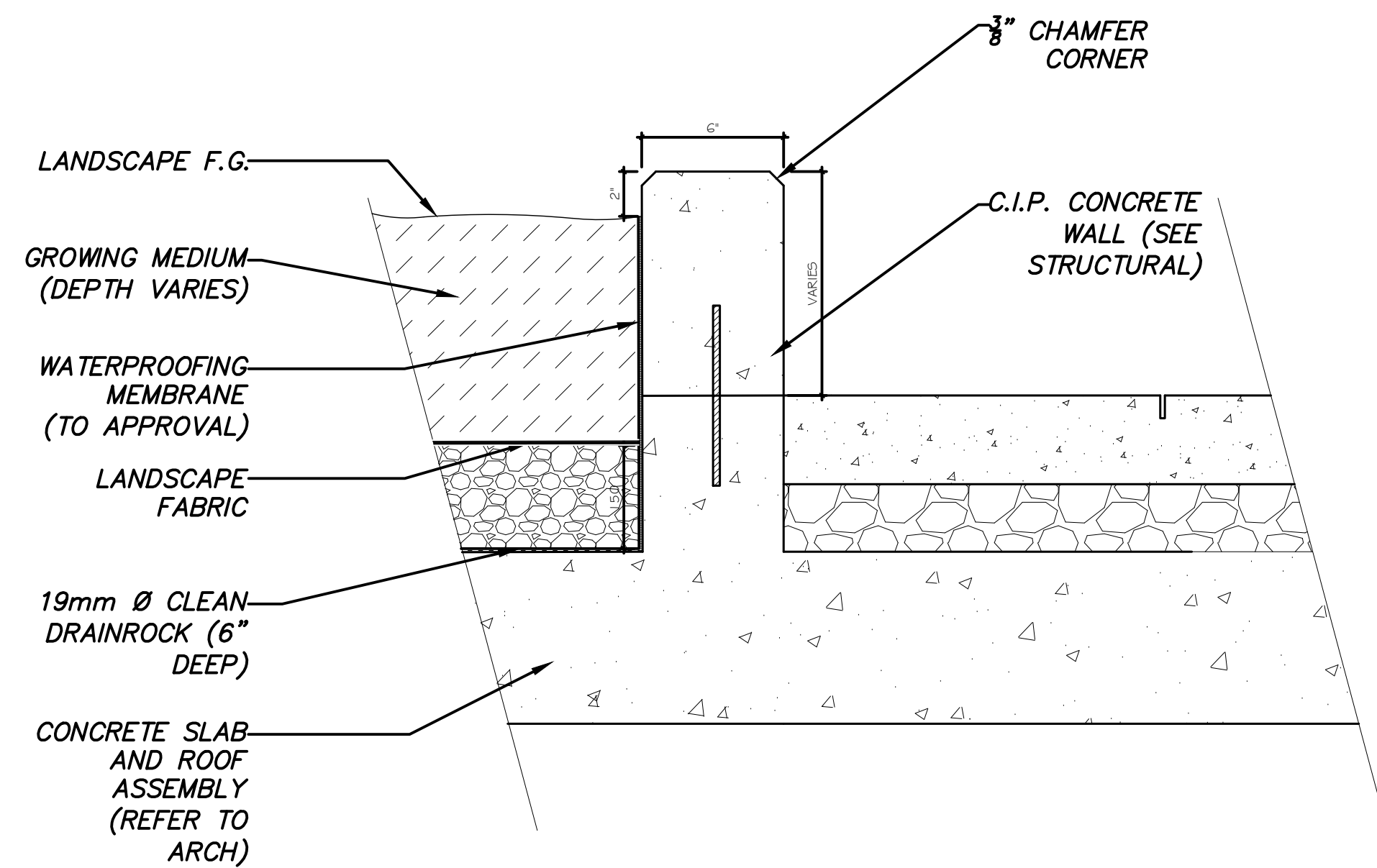

5 Typical Planter Wall
1-1/2" = 1'-0"

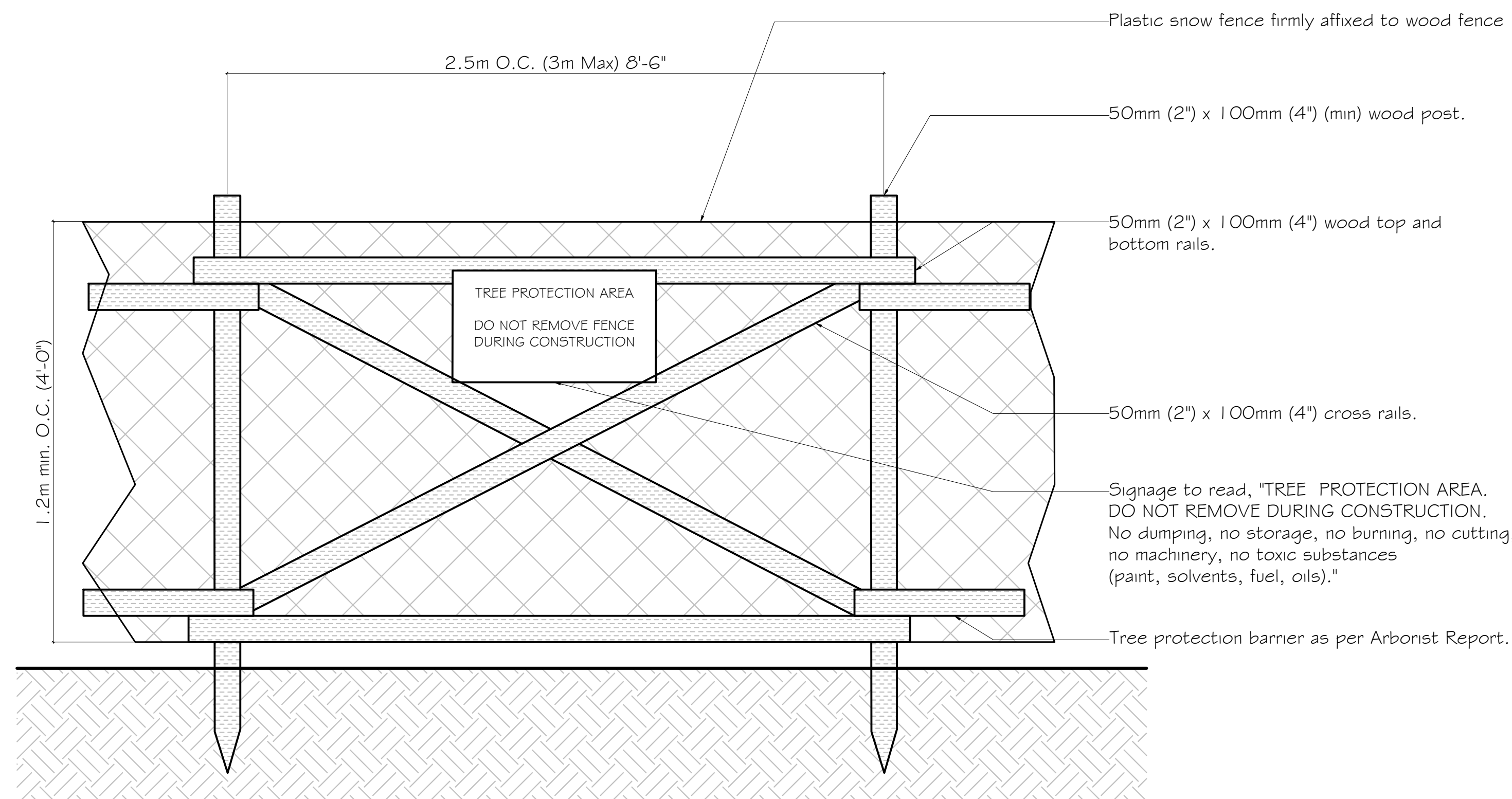

6 Typical Tree Barrier Details
3/4" = 1'-0"

PROJECT:

Carey Theological College
LOT 40 & LOT 42
5920 Iona Drive
Vancouver, BC

PROJECT NO.: DP 2022 0104

CONSULTANTS:

DRAWN BY:

KY

FILE NO.:

DATE:

2022.01.04

SCALE:

Varies

TITLE:

Landscape - Details

SHEET NO.: REVISION:

L-4.02

Copyright reserved

Everything shown herein for use on this project only and may not be reproduced without the Architect's written permission and unless the reproduction carries their name.

2	Issue for DP	2022.01.07
1	Development Application AUDP	2022.01.04
No.	Description	Date

SEAL:

PROJECT:

Carey Theological College

LOT 40 & LOT 42
5920 Iona Drive
Vancouver, BC

PROJECT NO.: **DP 2022 0104**

CONSULTANTS:

DRAWN BY:

KY

FILE NO.:

DATE:

2022.01.04

SCALE:

Varies

TITLE:

Landscape - Details

SHEET NO.:

REVISION:

L-4.04



TREE GRATE:

Type: Jamison
Size: 5' x 10' Rectangle
Colour: Recycled Aluminium Brushed Finish
Manufacturer: Urban Accessories
Website: www.urbanaccessories.com
Phone: 604-667-8141

1 Tree Grate
NTS

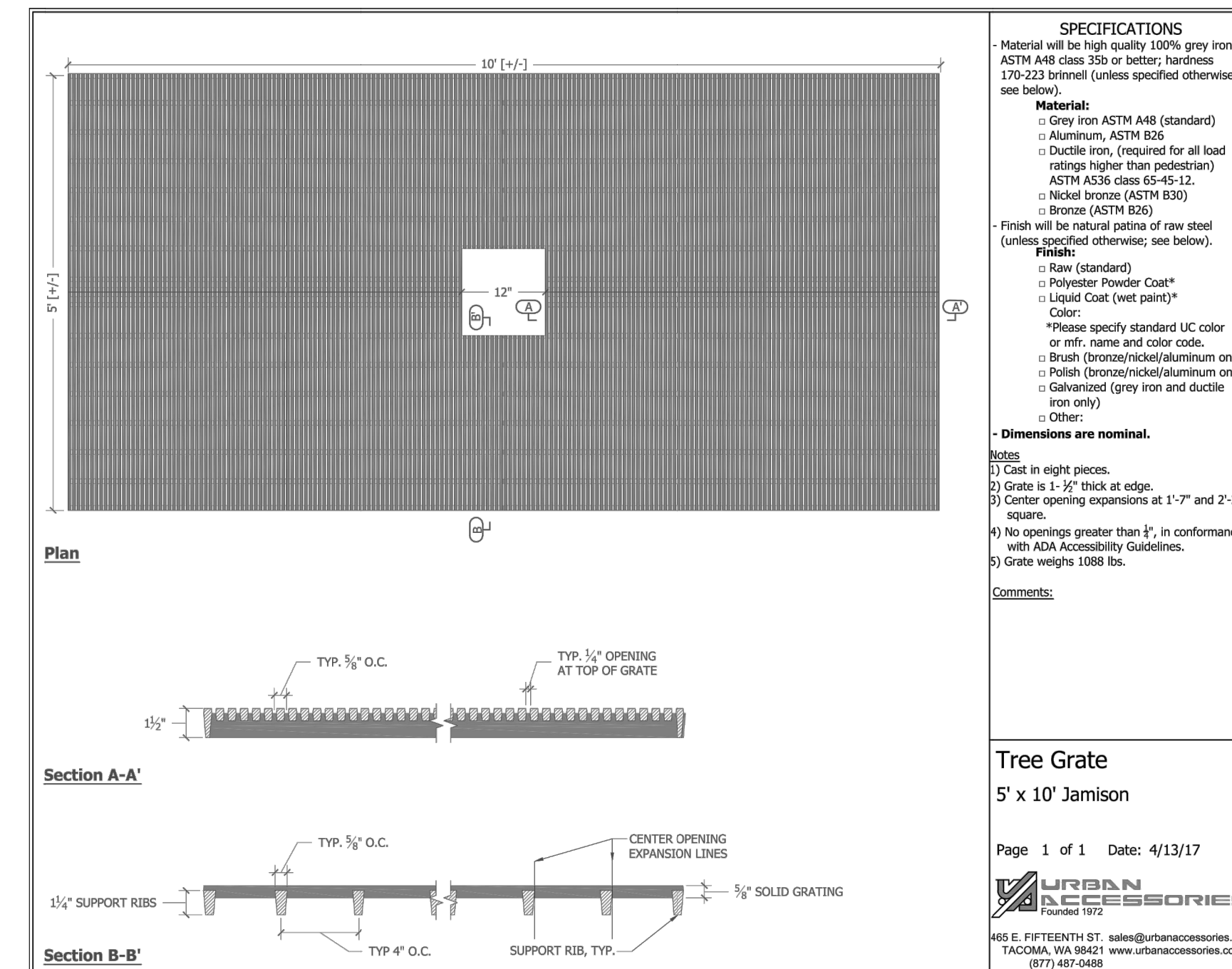

2 Tree Grate Details
NTS



TREE GRATE ROUND:

Type: Flat Rainbow
Size: 8' Dia.
Colour: Aluminium Brushed Finish
Manufacturer: Urban Accessories
Website: www.urbanaccessories.com
Phone: 604-667-8141

3 Round Tree Grate
NTS

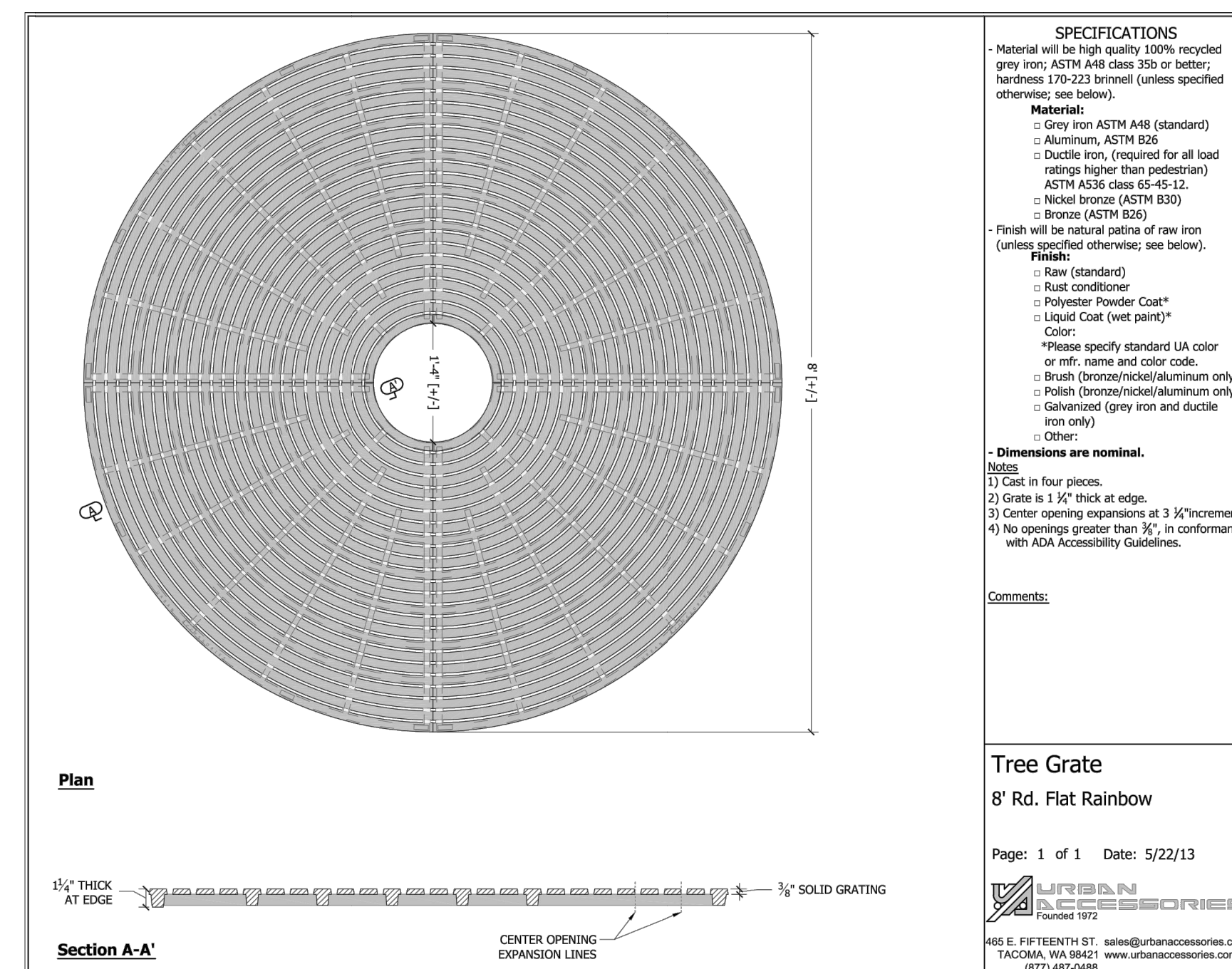

4 Round Tree Guard Details
NTS

Trees



CN - Pacific Dogwood



AR - Red Alder



GB - Ginkgo Tree



LS - Sweetgum Tree



AC - Vine Maple



PS - Amango Flowering Cherry



QR - Columnar English Oak



RP - Cascara



TB - Pacific Yew



PM - Douglas Fir

Climbing Vines

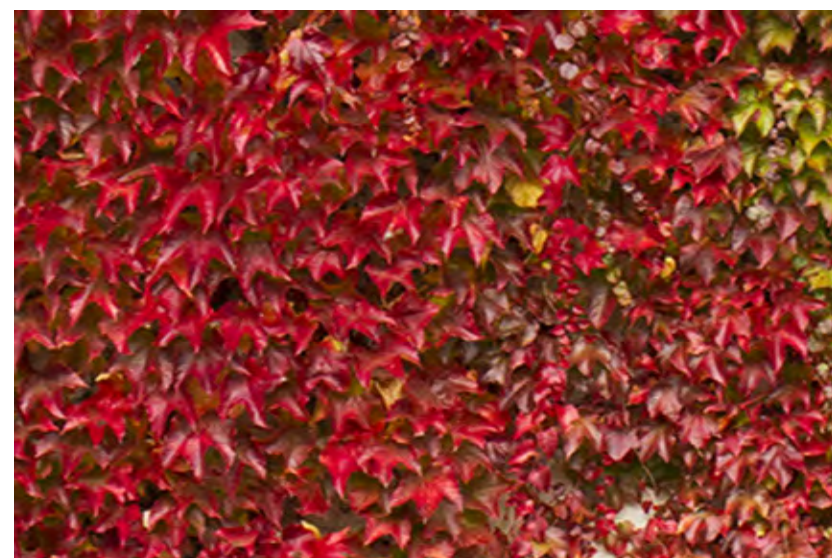

ptv - Boston Ivy

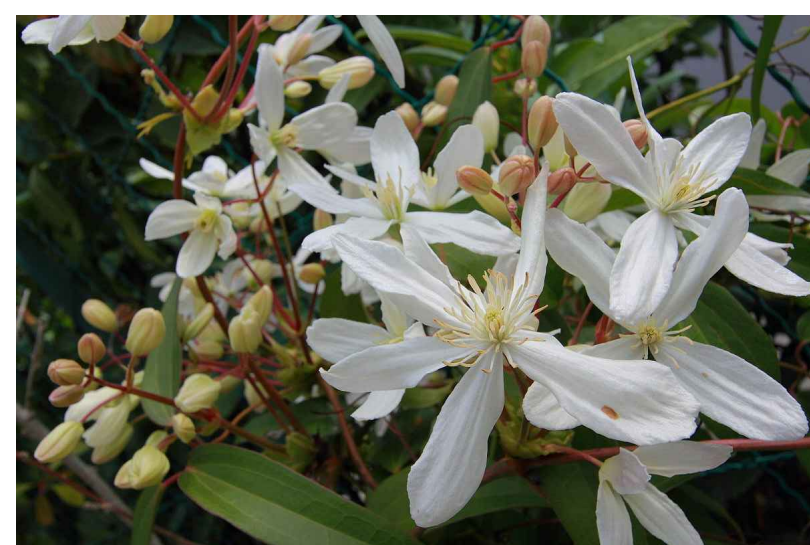

cav - Evergreen Clematis

Grasses and Ground Covers



js - Japanese Spurge



lm - Lily Turf

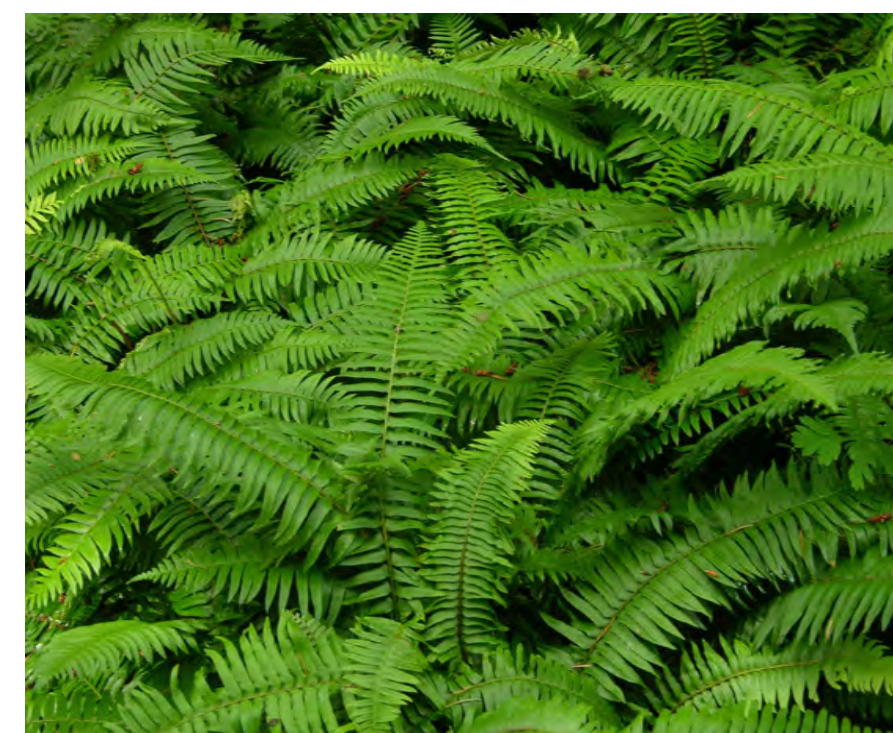

pm - Sword Fern



ph - Blackstem Bamboo



tc - Spreading Japanese Yew

Copyright reserved

Everything shown hereon for use on this project only and may not be reproduced without the Architect's written permission and unless the reproduction carries their name.

2	Issue for DP	2022.01.07
1	Development Application AUDP	2022.01.04
No.	Description	Date

SEAL:

PROJECT:

Carey Theological College

LOT 40 & LOT 42
5920 Iona Drive
Vancouver, BC

PROJECT NO.: DP 2022 0104

CONSULTANTS:

DRAWN BY:

KY

FILE NO.:

DATE:

2022.01.04

SCALE:

NTS

TITLE:

Landscape - Plant List Images

SHEET NO.:

REVISION:

L-5.00

Shrubs



bx - English Boxwood



ct - Mexican Orange



ma - Oregon Grape

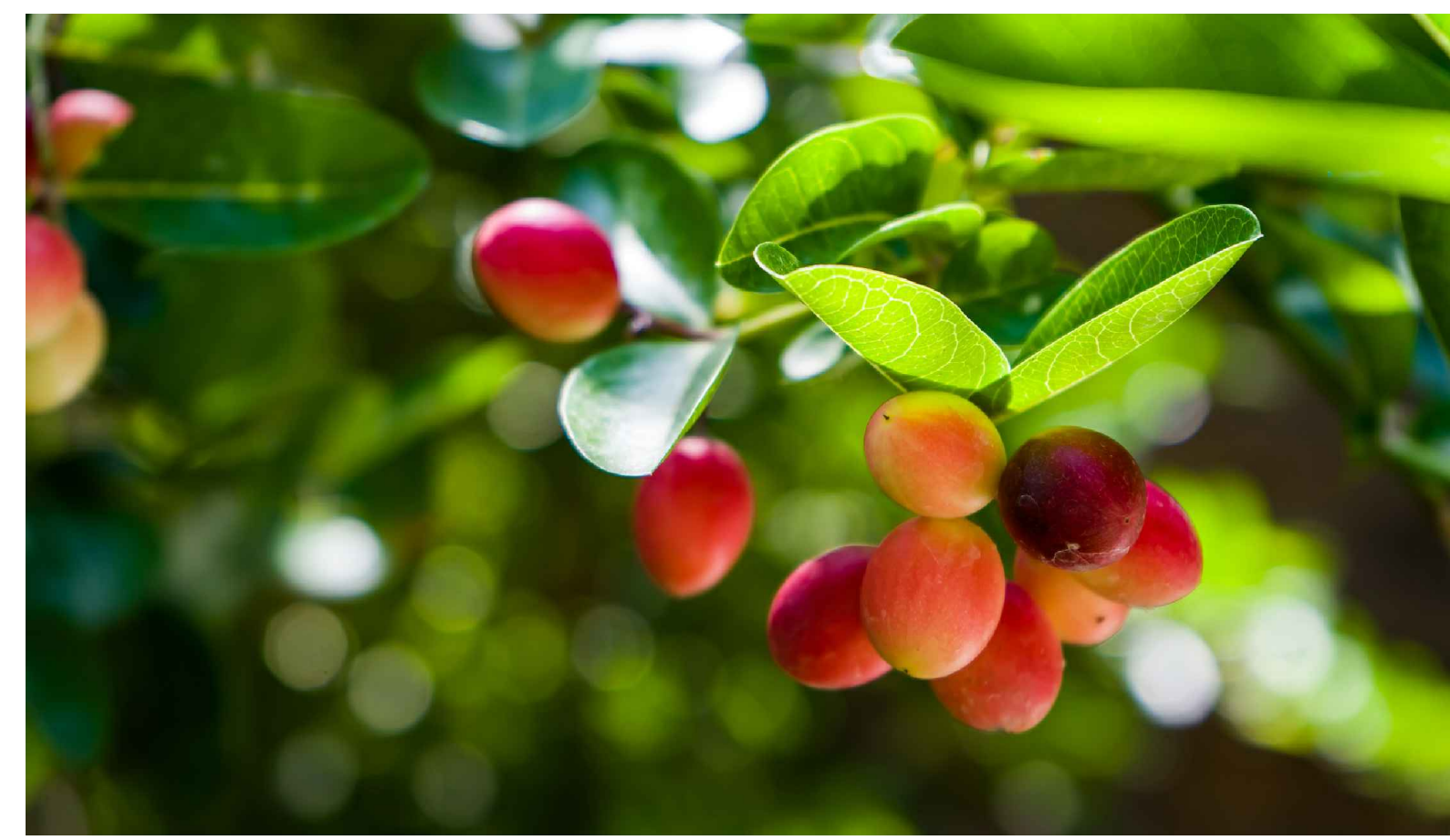

oc - Indian Plum

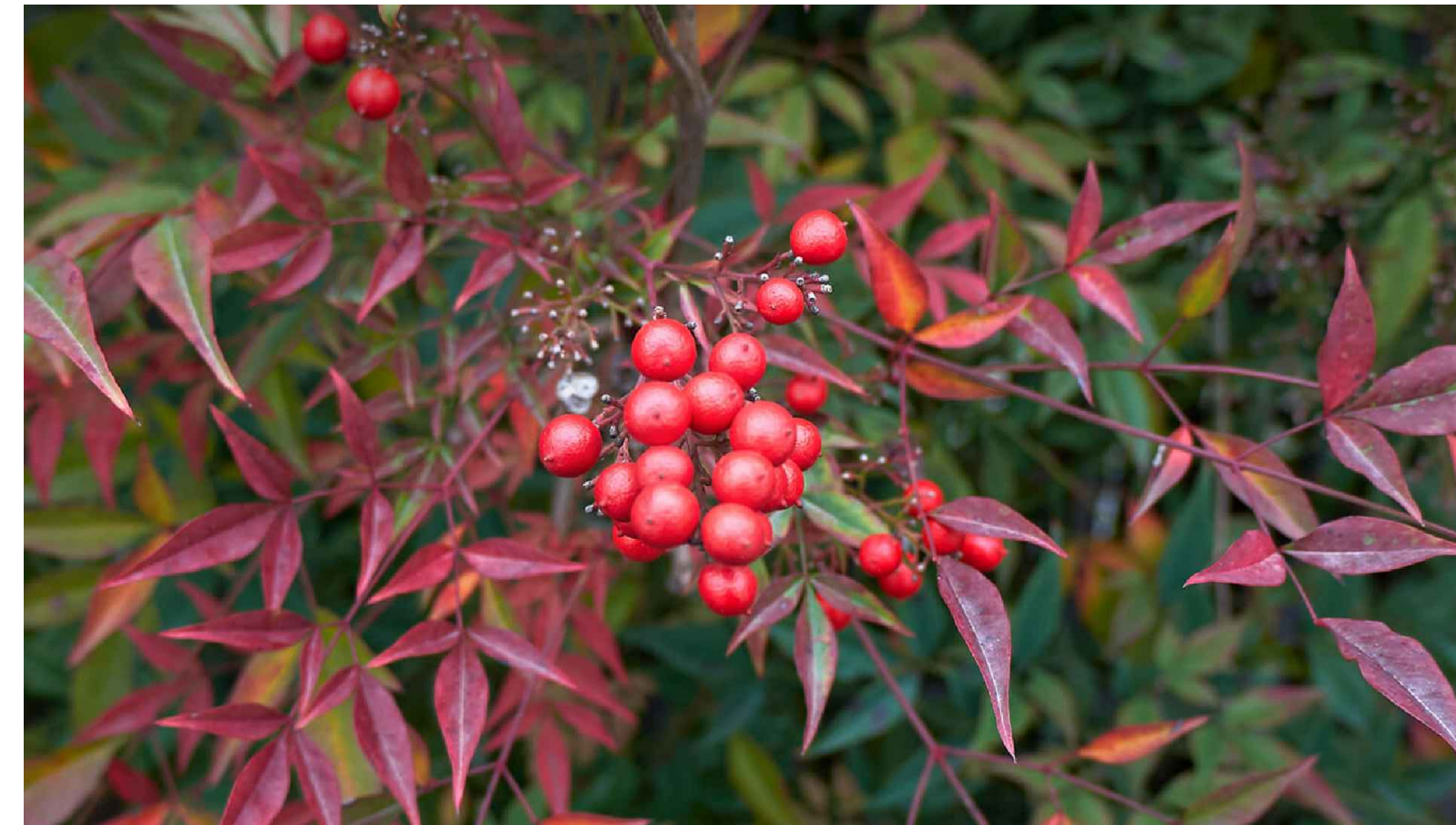

nd - Heavenly Bamboo



hd - Ocean Spray



hp - Climbing Hydrangea



gs- Salal



po - Otto Luykin Laurel



rht & rhm - Rhododendron



rn - Nootka Rose

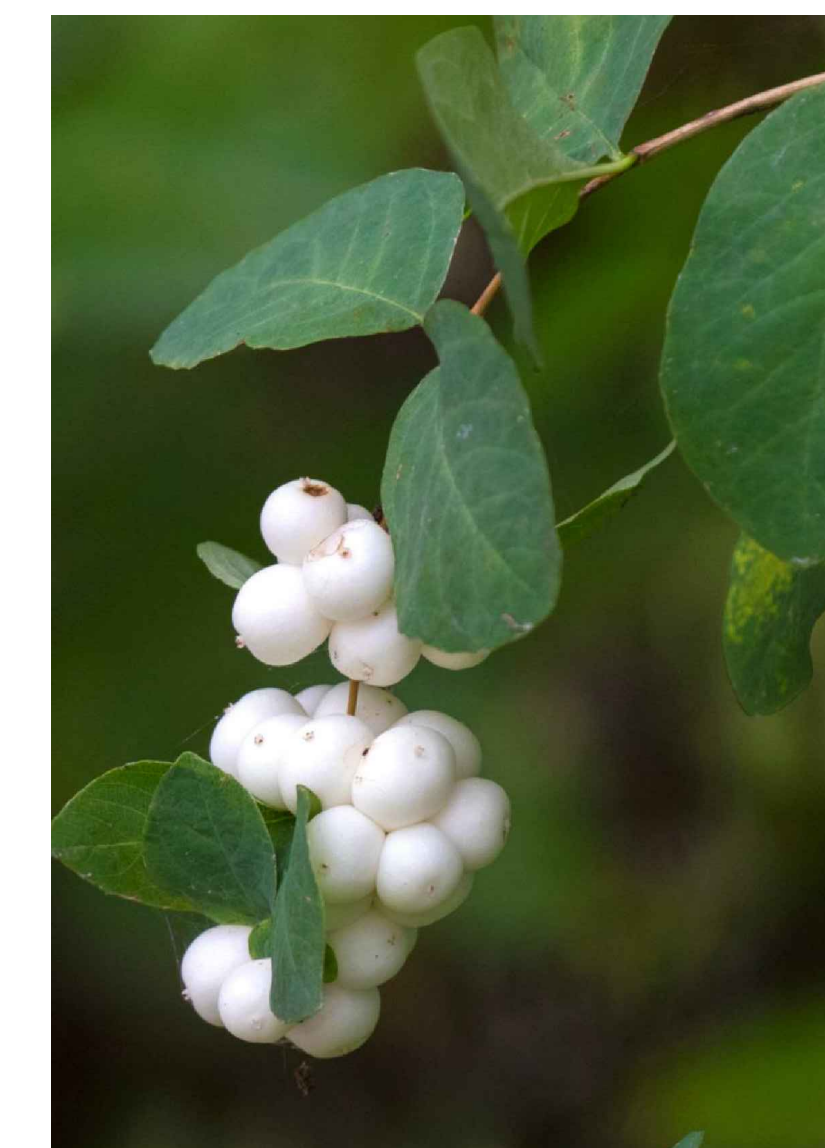

sa - Snowberry



pj - Forest Flame Pieris



sb - Goldflame Spirea



sd - Hardhack

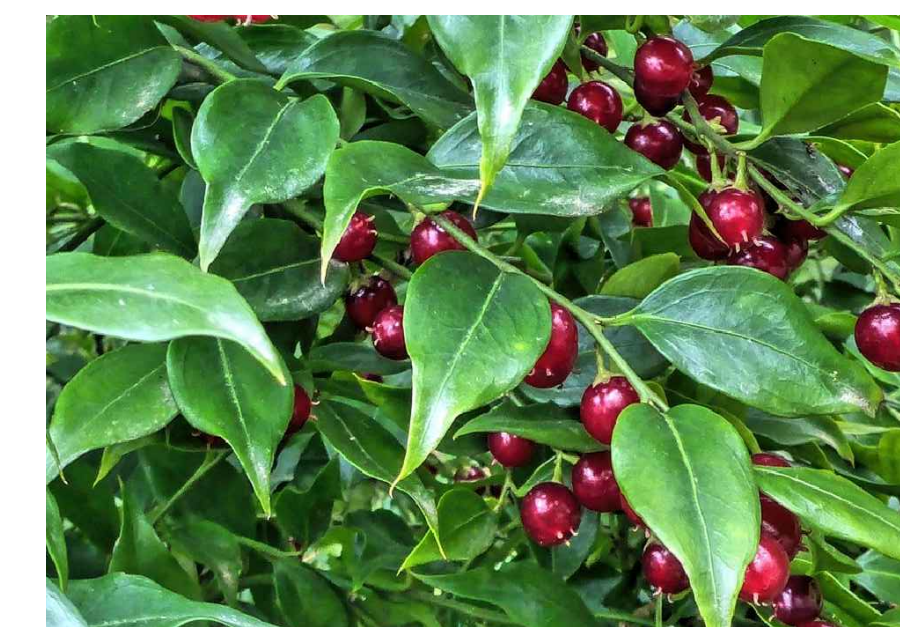

sh - Sweetbox



vp - Red Huckleberry



cs - Redtwig Dogwood



rs - Salmonberry

2	Issue for DP	2022.01.07
1	Development Application AUDP	2022.01.04
No.	Description	Date

SEAL:

PROJECT:

Carey Theological College

LOT 40 & LOT 42
5920 Iona Drive
Vancouver, BC

PROJECT NO.: **DP 2022 0104**

CONSULTANTS:

DRAWN BY:

KY

FILE NO.:

DATE:

2022.01.04

SCALE:

NTS

TITLE:

Landscape - Plant List Images

SHEET NO.:

REVISION:

L-5.01